



US Lacrosse National Headquarters  
113 West University Parkway • Baltimore, MD 21210  
Ph: 410.235.6882 • Fax: 410.366.6735  
www.uslacrosse.org

# US LACROSSE **MEN'S GAME**

## OFFICIALS EDUCATION PROGRAM



# 2014 TRAINING MANUAL

*An Official Publication of the National Governing Body of Lacrosse*



## **ACKNOWLEDGEMENT**

This manual is the result of the hard work and collaboration of the Men's Officials Training Group (Jim Carboneau, Robert Rinker, Paul Espinosa, Don Balch, David Bagdan, Matt Dempsey, Hank Friedman, Gordon Corsetti, Wayne Sanford and Lee Spitzer) and the staff of US Lacrosse that supports this group. It should be used as a resource for individuals and organizations alike. Knowledgeable competent officials are the cornerstone for the development of lacrosse across the country. It is our hope to continue to develop nationally standardized mechanics, so as teams and officials travel around the country to play and officiate, that they will encounter the same level of officiating and mechanics that ensures safety and fair play.

***Jim Carboneau***

***Men's Game Officials Training Group – Chair  
2013***

## **DEDICATION**

This manual is dedicated to all individuals who have taken up the call to officiate lacrosse. In a world where it has become vogue to blame everything bad on those who wear stripes, it is necessary to thank these individuals for their time and actions in improving their game and their determination to get the call right. We truly are the “third team” on the field, determined to enforce safety, sportsmanship and fair play among all those involved in the game.

***Good luck and thank you.***

## ABOUT THIS MANUAL

This manual mainly focuses on Two-person mechanics. However, a majority of the same or similar mechanics are used in three-man mechanics as well. This manual is designed to be a supplement to the US Lacrosse on-line course, classroom and on-field training. It is not the end-all-be-all of lacrosse officiating, but more of a guide and resource for officials to carry with them in their game bag throughout the season.

*The manual is composed of four main sections.*

### Introduction

Resources and information related to all levels of officials. Briefly outlines the training and certification requirements established by US Lacrosse and includes a list of resources established specifically for men’s game officials by US Lacrosse.

### The Game

Follows along directly with the national standard for officiating mechanics and the classroom PowerPoint your local US Lacrosse Certified Trainer will go through annually in your classroom section.

### Game Management

Information and resources that go beyond the basics of officiating covered in “The Game” section of this manual.

### Appendices

Additional resources and information from US Lacrosse that is invaluable to officials of all levels.

### New Interactive Layout

The new layout of this manual is to assist officials in utilizing this valuable tool throughout their season and career. We have added a notes section, rule references to the three main rule codes, and Quick Response Codes (better known as QR codes) to allow officials to access resources by a simple click or utilizing a free QR code reader on their smartphone.

**Quick Access Code  
(QR Code)**

You can access the link by either clicking on this (if viewing as a PDF on your computer) or by using a free QR Reader on your smartphone.

**Rule Reference Section**

References the US Lacrosse Youth Rules, NFHS and/ or NCAA rules related to the information on the page

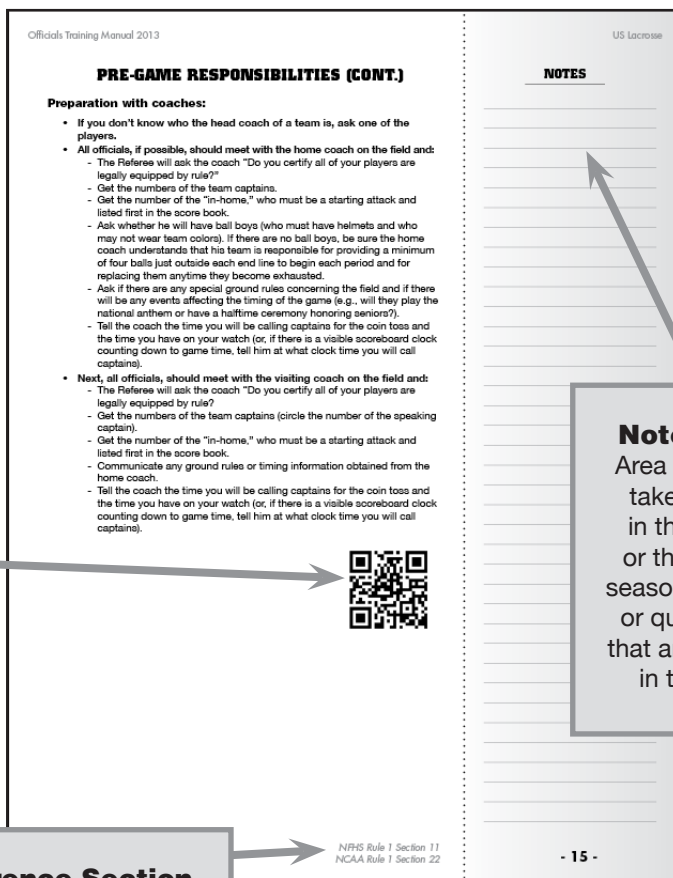

**Notes Section**

Area for officials to take notes while in the classroom or throughout the season as situations or questions arise that are not covered in this manual.

# CONTENTS

Acknowledgments .....	iii
About this Manual.....	iv
Contents .....	v
<b>Introduction.....</b>	<b>1</b>
US Lacrosse Men’s Game Officials Training.....	2
Professionalism .....	6
Uniform and Equipment.....	7
<b>The Game .....</b>	<b>9</b>
Glossary of Officiating Terms .....	10
The Field of Play .....	11
Mechanics .....	12
Pre-Game Responsibilities .....	13
Coin Toss .....	16
Pre-Game Line-Up .....	17
Face-Offs .....	18
Settled Situations .....	20
Stopping and Starting Play .....	21
Goal Scored and Readying the Ball for Face-off After Goal .....	22
Out of Bounds .....	23
Deep Restart with the Ball on Trail Official’s Side .....	24
Deep Restart with the Ball on Lead Official’s Side .....	25
Penalty Enforcement .....	26
Play On .....	27
Making the Decision: Whistle, Flag Down, or Play On? .....	28
Equipment Checks .....	29
Time Outs .....	32
Fight Procedures .....	33
Post-Game .....	34
Arm Signals .....	35
<b>Game Management .....</b>	<b>40</b>
Pre-game.....	41
Face-offs.....	42
Mechanics .....	43
Dead-ball Officiating.....	44
Communication.....	46
Dealing with Conduct Issues.....	47
Types of Games .....	50
The Principle of Advantage/Disadvantage .....	52
The Play-On .....	53
Mistakes by Officials.....	54

## CONTENTS

<b>Appendices .....</b>	<b>55</b>
Appendix I – Available Training tools .....	56
Appendix II – How Officials Honor the Game .....	57
Appendix III – US Lacrosse Code of Conduct .....	58
Appendix IV – US Lacrosse Benefits for Officials .....	63
Appendix V – Fouls Decisions Tree .....	60
Appendix VI – USL One Page Pre-Game for Officials .....	62
Appendix VII – US Lacrosse Junior Officials Evaluation Form .....	63
Appendix VIII – Level 1 US Lacrosse Officials Evaluation Form .....	65
Appendix IX – Level 2 US Lacrosse Officials Evaluation Form .....	67
Appendix X – Level 3 US Lacrosse Officials Evaluation Form .....	69



US LACROSSE  
OFFICIALS  
EDUCATION  
PROGRAM

**INTRODUCTION**

## US LACROSSE MEN'S GAME OFFICIALS TRAINING

As the sport of lacrosse grows and evolves, so do the rules and mechanical procedures at all levels of the game. The purpose of the US Lacrosse Officials Education and Training Program is to develop knowledgeable and prepared lacrosse officials at every level of the game.

In order to achieve this, officials must:

- **Undergo continued standardized training in order to stay current with the game**
- **Always consider the level of play when officiating**
- **Promote the safety of participants**
- **Promote fair play and sportsmanship**
- **If desired, work to improve their certification level and qualify for higher level games and “move up” to higher levels of officiating**



*Men's Officials  
Information*

US Lacrosse training has been developed – and continues to improve – with these goals in mind.

### Considering Level of Play

The US Lacrosse Officials Training and Education program is designed with consideration for officiating at different skill levels. While there are many similarities from level to level, from an emphasis on safety and sportsmanship to the mechanics for basic field positioning, there are many important differences, including – but not limited to – the rules. Curriculum guides will be available to trainers to guide their instruction by level of play, based on differences in rules, interpretations, and points of emphasis from one level of play to the next. It is important that officials understand and embrace these skill differences when officiating at each level of play.

### Career Progression

Due to the current shortage of officials, career progression in the lacrosse community can be rapid. Officials trained at Levels 1 and/or 2 are sure to find opportunities to officiate youth or scholastic games in their first few years. It takes a few years to develop a strong Level 2 official and usually another few years to develop a strong Level 3 official. Once an official is Level 3 certified, application may be considered for the college ranks. After attaining a college-level ranking, opportunities to officiate post-collegiate club and international lacrosse games await the experienced and dedicated lacrosse official. Opportunities for advancement differ from region to region; ask your local USL Trainer about the requirements for career progression in your district.

### Hands-On Experience

In addition to your local training, US Lacrosse Education and Training Programs provide additional clinic opportunities that take place around the country. Your USL Trainer will share information with you regarding participation in these opportunities. US Lacrosse also sponsors LAREDO (LAcrosse REfreee Development Opportunities) to meet these needs at a more national level. LAREDO utilizes regional lacrosse tournaments and summer lacrosse camps as sites for intense and concentrated lacrosse officiating development. The philosophy behind the LAREDO program is to make these clinics accessible to all lacrosse officials from around the country. This balanced representation enables officials from developing and established areas, to polish their officiating skills under the instruction of a USL Clinician. Your local US Lacrosse training program will prepare you to participate in LAREDO.

**There are distinct advantages to LAREDO training programs:**

- **Officials gain access to appropriate levels of competition when they are ready for advanced training.**
- **New officials can gain additional more advanced two-man experience.**
- **Established officials can upgrade their three-man skills through regional lacrosse tournaments, and advanced officials can further polish their techniques by participating in elite tournaments.**
- **The nationwide standardization of mechanics and rules interpretations are reinforced.**
- **Knowledge is multiplied, as officials return to their respective US Lacrosse Districts and share their advanced officiating experiences with their colleagues.**
- **Camaraderie develops as officials interact on national crews.**
- **Officials gain national exposure.**
- **Many opportunities are available to you—please work with your local trainer to find out more about how to maximize your officiating experience and opportunities.**



*US Lacrosse  
LAREDO Programs*



## US LACROSSE MEN'S GAME OFFICIALS TRAINING

- To promote the safety of all parties (players, coaches, bench personnel, officials).
- To promote fair play and sportsmanship.
- To standardize officials mechanics.
- To recruit, train, and retain officials who are providing a safe and fun game experience at every level they officiate.
- To encourage the growth of the sport and to honor the game.

### LEVEL 1

#### Goals and Objectives of US Lacrosse Level 1 Training

US Lacrosse Level 1 training is targeted at officials with little or no experience in officiating men's lacrosse. The goal of Level 1 Training is to introduce officials to the basic rules and mechanics necessary to facilitate a safe and fair game. Level 1 Training is primarily intended to equip officials to work games at the U-15 scholastic level and lower youth levels.

Level 1 training prepares officials to:

- Properly prepare individually and with a partner in advance of contests.
- Maintain a safe playing field at each contest.
- Establish an assertive presence on the field.
- Communicate effectively using voice and hand signals:
  - With a partner.
  - With coaches and the scorer's table.
- Conduct the pre-game coin toss and line-up procedures.
- Understand and correctly demonstrate basic field positioning.
- Correctly identify if a team has possession of the ball in a penalty situation and how to apply the slow whistle technique.
- Understand and recognize differences between personal and technical fouls.
- Recognize and assess safety fouls accurately and fairly.



*Level 1 Certification Requirements*

#### Level 1 Certification Requirements

In order to be Certified Level 1 by US Lacrosse, officials must complete the minimum requirements listed below:

- Current "official" member designation with US Lacrosse
- Online Course
- Classroom (8 hours minimum) Best Practice over 3 to 4 Sessions
  - o Three hours minimum focused on mechanics
  - o Five hours minimum focused on rules and lacrosse officiating knowledge
- Field work (no time limit, needs to pass level 1 evaluation) –
  - o Recommended 2 games as a shadow, 2 games being shadowed, and 2 games solo with senior partner. (Evaluation should be done without a shadow)
  - o It may be necessary to evaluate one official multiple times before certification is achieved
  - o Evaluation reported by trainer as completed and passed to US Lacrosse
- Take online and pass the US Lacrosse annual rules test with an 80 or higher

In addition all officials who are Level 1 Certified and wish to remain Level 1 must meet annual recertification requirements in order to maintain their Level 1 Certification. These requirements are:

- Pass the annual US Lacrosse Rules test with an 80 or higher
- Classroom (6 hours minimum)
  - o Two hours minimum focused on mechanics
  - o Four hours minimum focused on rules and lacrosse officiating knowledge

# US LACROSSE MEN'S GAME OFFICIALS TRAINING

## LEVEL 2

### Goals and Objectives of US Lacrosse Level 2 Training

Level 2 training is targeted at men's lacrosse officials with field experience and an understanding of basic rules and mechanics. The goal of Level 2 is to advance officials' knowledge and application of rules, mechanics and game management. Level 2 Training is primarily intended to equip officials to work games at the high school level and lower.

Level 2 training reinforces Level 1 concepts and prepares officials to:

- **Maintain a safe playing field at each contest**
- **Establish a confident, professional and assertive presence on the field**
- **Communicate effectively with a clear, commanding voice and with demonstrative hand signals:**
  - With a partner
  - With players
  - With coaches and the scorer's table
- **Understand and correctly demonstrate advanced field positioning**
- **Correctly perform equipment inspections**
- **Properly enforce the rules regarding 10- and 20-second counts**
- **Apply the stalling rules**
- **Correctly identify which team has possession of the ball in a penalty situation and the sequence of fouls as they occur**
- **Understand, recognize and assess all fouls, including simultaneous fouls and fouls that create an advantage**
- **Recognize advantage/disadvantage in loose ball situations and when the play-on technique is required**
- **Assess all fouls accurately and fairly**



*Level 2 Certification  
Requirements*

### Level 2 Certification Requirements

In order to be Level 2 Certified Trained by US Lacrosse, officials must complete at minimum the requirements listed below:

- **Must have a current Level 1 certification or have met all requirements for Level 1 certification and is being field evaluated for Level 2 certification.**
- **Current "official" member designation with US Lacrosse**
- **Classroom (6 hours minimum)**
  - o Two hours minimum focused on mechanics
  - o Four hours minimum focused on rules and lacrosse officiating knowledge
- **Field work – (no time limit, needs to pass level 2 evaluation)**
  - o Level 2 on-field evaluation
  - o Evaluation reported by trainer as completed and passed to US Lacrosse
  - o It may be necessary to evaluate one official multiple times before certification is achieved.
- **Take online and pass US Lacrosse annual rules test with a 90 or higher.**

Additionally, all officials who are Level 2 Certified Officials and wish to remain Level 2 must meet annual recertification requirements in order to maintain their Level 2 Certification. These requirements are:

- **Take online and pass the US Lacrosse annual rules test with a 90 or higher**
- **Classroom (6 hours minimum)**
  - o Two hours minimum focused on mechanics
  - o Four hours minimum focused on rules and lacrosse officiating knowledge

# US LACROSSE MEN'S GAME OFFICIALS TRAINING

## LEVEL 3

### Goals and Objectives of US Lacrosse Level 3 Training

Level 3 training is targeted at men's lacrosse officials with field experience and officials who are currently Level 2 officials. The goal of Level 3 is to advance officials' knowledge and application of rules, mechanics and game management. Level 3 Training is focused on three-man mechanics and is primarily intended to equip officials to work games at the high school level and prepare them for eventually becoming a collegiate official.

Level 3 training reinforces Level 2 concepts and prepares officials to:

- **Excel at officiating games utilizing three-man mechanics**
- **Focus on advanced game management techniques**
- **Establish a confident, professional and assertive presence on the field**
- **Communicate effectively with a clear, commanding voice and with demonstrative hand signals:**
  - With a partner
  - With players
  - With coaches and the scorer's table
- **Learn how to properly mentor and work with Level 1 and 2 officials as the Crew Chief**
- **Understand, recognize and assess all fouls, including simultaneous fouls and fouls that create an advantage.**

### Level 3 Certification Requirements

- **Current Level 2 certification (official cannot jump from a Level 1 to a Level 3 without first being certified as a Level 2 official)**
- **Current "official" member designation with US Lacrosse**
- **Classroom – 6 hours**
  - o Two hours minimum focused on mechanics
  - o Four hours minimum focused on rules and lacrosse officiating knowledge
- **Field work - (no time limit, needs to pass level 3 evaluation)**
  - o Level 3 on-field evaluation form
  - o Must achieve a score of 80 or higher on the evaluation score
  - o Reported by trainer and reported to US Lacrosse as passed
- **Take online and pass the Us Lacrosse annual rules test with a 90 or above**

In addition, all official who are already Level 3 Certified Officials and wish to remain Level 3 must meet annual recertification requirements in order to maintain their Level 3 Certification. These requirements are:

- **Take online and pass the US Lacrosse annual rules test with a 90 or higher**
- **Classroom (6 hours minimum)**
  - o Two hours minimum focused on mechanics
  - o Four hours minimum focused on rules and lacrosse officiating knowledge
- **Official must have accumulated 20 hours of active participation throughout previous certification year.**
  - o This can be met by games worked, observing Level 1 and 2 officials, conducting local training, mentoring junior officials etc...
  - o LOA can define the exact requirements on how officials can reach the 20 hours using the above examples as a guideline.



*Level 3 Certification  
Requirements*

## **PROFESSIONALISM**

**Being a professional means more than being on time and attired in the correct uniform. Mastering the following areas will help you present yourself professionally:**

**Conditioning:** You must be in shape to meet the demands of the game, in terms of speed and endurance. You can't make the right calls if you can't get into position to make them, or if physical strain is affecting your decision making ability.

**Rules knowledge:** It can take years to fully understand the rules. Continual review of the rules as an official will help you to develop more quickly.

**Mechanics:** Officials need to know more than the rules: they also need to know where to go on the field and what their responsibilities are.

**Game management:** There are many times that officials can keep the game running smoothly without using their flag and whistle. Game management techniques are discussed throughout this manual; master them, and you'll find that officiating becomes much easier.

**Communication:** Communication is a key aspect of game management. Communicate with your partner, the coaches, and the bench personnel in a clear and efficient manner.

**Conduct:** Demonstrate the appropriate demeanor; treat your partner, the table personnel, athletes, and coaches with the respect that you desire to receive. Aloofness, indifference, boredom, and disdain are worse behaviors than nervousness; strive to be engaged at all times.

**Confidence:** Confidence comes from preparation and experience. You must know the rules, interpretations and mechanics in order to be prepared for any situation.

**Focus:** Concentrate on what you are doing, and do not lose your focus on the game. Block out distractions and move on to the next situation that is happening in front of you. Don't let thinking about a call you might have missed interfere with getting the next call right.

**Consistency:** Be the same at both ends of the field, and try to complement your partner by calling fouls at the same threshold.

**Courage:** You must have the courage to do what is right. Whether it's a difficult call or a difficult "no-call," you won't be a successful official without the fortitude to "get it right!"

**Uniform and equipment:** As an official, you should have the proper uniform, and it should be neat and clean. You must also have the proper equipment for your level of play. If you don't, you'll be battling a negative impression from the start.

## UNIFORM AND EQUIPMENT

US Lacrosse requires the following uniforms for the corresponding levels of the game. Uniform standards exist to communicate the level of professionalism that officiating associations aspire to maintain. Crew members should coordinate all uniform parts when possible.

College	Scholastic	Youth	<b>Uniform requirements by different levels of the game</b>
✓	✓	✓	Short sleeved shirt: One-inch vertical stripes on the body and sleeves. A black collar and black cuffs are required. Basketball style referee shirts are prohibited.
✓	✓		Long sleeved shirt: One-inch vertical stripes on the body and sleeves. A black collar and black cuffs are required.
✓	✓	✓	Shorts: Black shorts with 4 pockets and belt loops. A minimum 6-inch inseam is required. If compression shorts are also worn, they must be black and may not extend below the hem of the shorts.
✓	✓	✓	Belt: Black belt, 1-2inches thick, with a plain silver buckle
✓	✓	✓	Undershirt: All undershirts and turtlenecks are to be solid black.
✓	✓		Jacket: Solid All Black Jacket
✓			Long Pants: Solid black nylon pants with zipper leg closures. Sweat pants are not permissible.
✓	✓	✓	Socks: Black “ankle” socks. The sock should cover the ankle bone. “No-show” and “crew socks” are prohibited.
✓	✓	✓	Shoes: Shoes must be all black with black laces.
✓	✓	✓	Hat: Hat must be black with 1/8th inch white piping (a sized or fitted hat is preferred).
✓	✓	✓	Flag Patch: The US Flag Patch is to be worn by all officials at all games (including USILA and MCLA games). This patch is worn centered on the left breast pocket and with the bottom of the patch ¾ inches above that pocket.
✓	✓	✓	Patch: The “US Lacrosse Collegiate Certified” Patch must be worn on the left sleeve for all collegiate games except NCAA playoff games. All other officials shall wear the “US Lacrosse Official” patch on the left sleeve for scholastic and youth level games unless directed otherwise by the local association or state association. The top of the patch should be roughly 3 inches down from the shoulder seam.
✓	✓	✓	Whistles: Officials whistles are black in color. A black Fox 40 finger whistle (pea-less) is required for its clarity and power.
✓	✓	✓	Penalty flags: Officials flags are solid gold with a centered weighted portion added in a safe manner. Two flags shall be carried in the front of the uniform, tucked into the waistband of the shorts.
✓	✓	✓	Coin: A coin at least the size of a half-dollar is needed for doing the coin flip.
✓	✓	✓	Tape Measure: All officials must have a pocket tape measure capable of measuring up to 72 inches. Tape measures should be black.
✓	✓	✓	20-second timer: A special 20-second timer for lacrosse officials is required for NFHS and NCAA games.
✓	✓		Equipment Bag: Officials are encouraged to carry their equipment in black bags, which must be neat in appearance.
✓			Gloves: When the weather is cold, officials have the options of wearing black gloves.



*Uniform and Equipment Checklist*





US LACROSSE  
OFFICIALS  
EDUCATION  
PROGRAM

**THE GAME**

## **GLOSSARY OF OFFICIATING TERMS**

On official	Official who is watching the ball.
Off official	Official who is watching the action away from the ball.
Lead official	Primary responsibility is the goal area (crease and goal line) and end line coverage.
Trail official	Stays behind the play, helping to keep the ball between him and the Lead official. This official would have the 4-second goalie count (if used); any clearing counts (if used) and would assist the Lead official with any offensive counts (if used).
Goal area	Defined by the 35-yard by 40-yard rectangle around the goal at the attack end of the field. Attack area is also known as the box.
Goal line extended (GLE)	Imaginary line running through the goal line and extending from sideline to sideline.
The alleys	The 10-yard by 35-yard strips on either side of the attack area.
Play-on	A mechanic and call used to indicate a loose ball technical violation and some violations concerning the crease area and goalkeeper interference.
Clearing team	The team attempting to move the ball from the defensive end of the field to its offensive end.
Riding team	During a clear attempt, the team not in possession of the ball.
In-Home	A starting attack-man. If players listed in the official score book are listed as Attack, Midfield, Defense, Goalkeeper then he is the first attack-man listed. This person must serve all penalties against his team that are not assigned to a specific player or any time serving fouls called against the coach staff.
Wing Areas	Lines parallel to the sidelines, 20 yards from the center of the field and extend 10-yards on either side of the midfield line, define this space to the sideline as the wing area.
Player possession	When a player has control of the ball in his crosse so that he is able to perform any of the normal functions of control, such as carrying, cradling, passing or shooting.
Flag down	A term used by officials to indicate that there will be a time serving foul.
Midfield "X"	The location on the field where all face-offs occur.



# THE FIELD OF PLAY

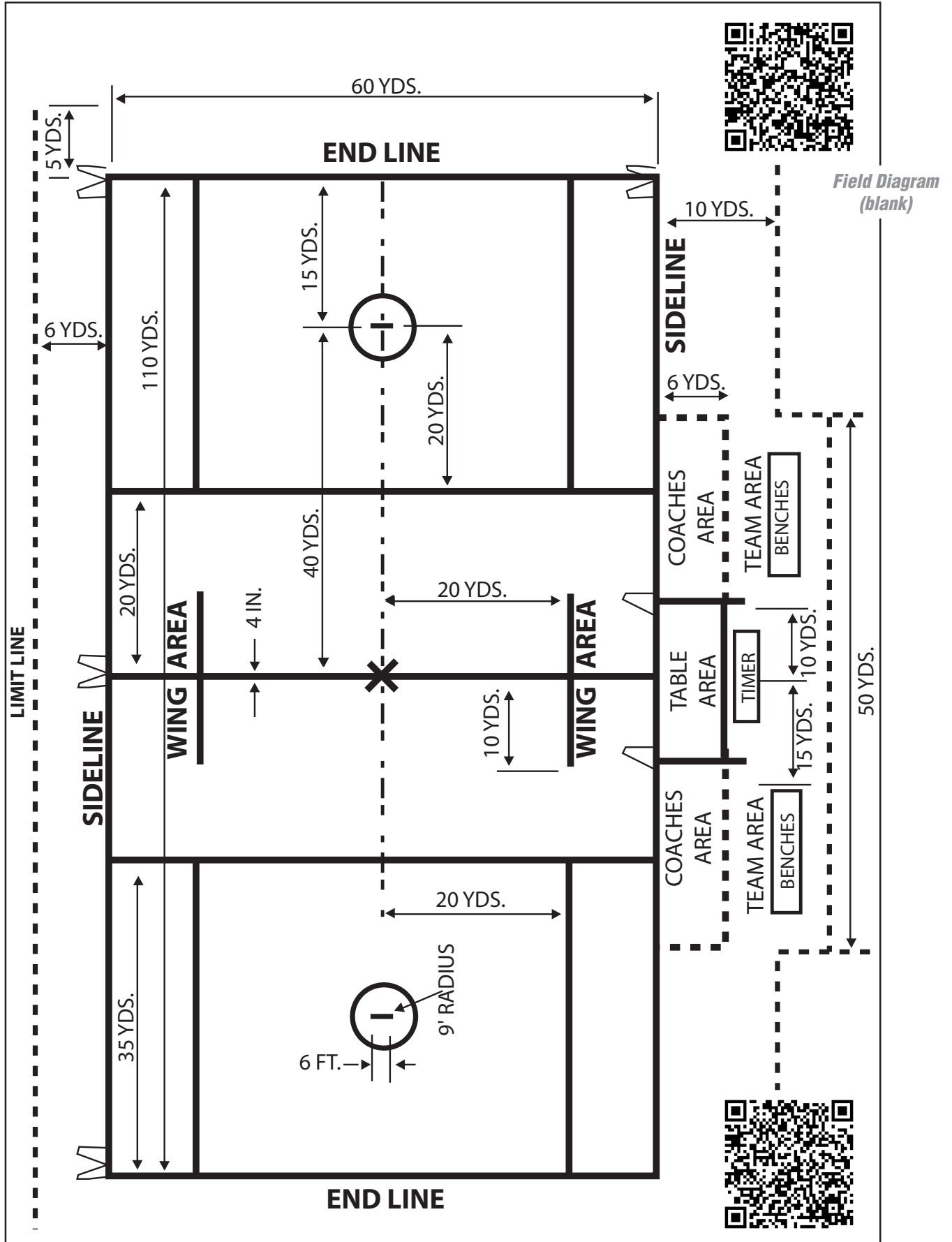

Field Diagram (dimensions)

Field Diagram (blank)

**NOTES****MECHANICS**

The term “mechanics” refers to the techniques the officials use to accomplish their jobs by them knowing the proper positions to be in depending on where the ball and action on the field is. While knowing the rules is an important aspect of officiating, knowing the proper mechanics and where to go on the field allows players, coaches, fans, and your partner to understand your calls. By having standard mechanics, it is possible for two officials who have never met before to step onto the field and work together seamlessly.

This manual focuses on Level 1 and Level 2 training, which is primarily concerned with two-man mechanics. Two-man mechanics are used for most youth and high school games.

In two-man mechanics, one official is designated the “Lead” and the other is the “Trail”; these designations switch when team possession, and subsequently field position changes. Depending on where the ball is, either the Lead or the Trail can be designated the “on” official (the one who watches the ball); the other is called the “off” official and watches activity away from the ball. They divide up the responsibilities—depending on who is the Lead and the Trail, and who is the “on” and “off” official—so each official is responsible for calling certain rules violations and for watching certain areas of the field. These responsibilities will be covered in detail in the pages that follow.

Typically, each official will stay on one side of the field (bench side or far side) for half of the game, switching sides at halftime. However, in running-time games where the teams only switch sides at halftime, the officials will stay on the same side of the field for the entire game. The key idea is that each official should be the lead when each team is on offense for half the game.

***This manual follows directly along with the US Lacrosse Two-Man Mechanics PowerPoint presentation which can be found by following the QR code below.***



***Two-Man Mechanics  
Powerpoint***

# PRE-GAME RESPONSIBILITIES

### Personal Preparation:

- **Uniform and equipment are clean and in good order.**
- **Review the rules and any modifications covering that game.**
- **Arrive at the game site with an adequate time cushion. Be ready both physically and emotionally. On the way to the game, mentally prepare yourself; if there is time also do this with your partner**
  - Examples of things you may want to discuss with your partner or go over with yourself prior to the game:
    - \* *Rule Interpretation*
    - \* *Things you are personally working on*
    - \* *Situations where you like help*
    - \* *Improvements you want to make from previous games*
    - \* *Any strange situations you have encountered this season*

### Communicate with partner:

- **By telephone or e-mail (24-48 hours before the contest):**
  - Confirm the time and location of the game.
  - Confirm the time and location of meeting.
  - Confirm consistent uniform: long pants or shorts; long- or short-sleeved shirt.
- **At the meeting site (ideally 45-60 minutes before the contest):**
  - The designated referee for the game should lead the pre-game meeting.
  - Review any new rules for the year and the rule exceptions for this game.
  - Discuss any pertinent information (e.g., field, teams, coaches, weather).
  - Review field mechanics.
- **On the field (20-30 minutes before the contest):**
  - Enter the field as a team.
  - Be fully prepared and in the appropriate uniform.
  - When greeting and meeting coaches answer any questions or concerns professionally and respectfully.

### Field Inspection:

- **Keep safety as your reference point on all decisions.**
- **Look for safety issues on the field:**
  - Holes
  - Mud
  - Water
  - High grass
  - Debris
  - Loose equipment
  - Sprinkler heads
  - Immovable objects near field
- **Adjacent areas:**
  - The benches should be well behind the coaches' areas
  - The table should be at least 6 yards from the sideline
  - Spectators must be at least 6 yards from far sideline
  - No spectators are permitted behind the end line
- **Check field lines, goals, nets, and creases well before the scheduled start time.**
- **Re-check the nets just after the coin toss for new holes (created by the teams' warm-ups) and for balls left in the goal.**



*Pre-Game Checklist*

## NOTES

---



---



---



---



---



---



---



---



---



---



---



---



---



---



---



---



---



---



---



---



---



---



---

**NOTES**

**PRE-GAME RESPONSIBILITIES (CONT.)**

**Preparation with table:**

- **Table personnel:**
  - The home team must provide the official timer and the official scorekeeper.
  - Identify who will perform each role.
  - Do they have experience?
    - \* *If they are inexperienced go over their roles and responsibilities*
- **Check clock:**
  - Is it operational?
  - Will the scoreboard clock be used or will the time be kept at the table?
  - Does the timer know how to operate it?
  - If a score board is used, does the score board have an operational horn that goes off at 'zero'?
    - \* *If not, referee should explain that the horn for substitutions should be used when the time gets to 'zero'.*
- **Review:**
  - Start and stop on whistle.
  - Length of quarters.
  - End-of-period procedure.
- **Penalty Clock:**
  - Explain your communications with them.
  - Go over the two conditions of release.
  - Cover "early" release procedures.
- **Horn:**
  - When is a horn allowed for substitution?
  - What if a horn is requested at an improper time?
- **If there is a problem:**
  - Note who has the ball, where the ball is, and what the problem is,
  - Sound a double horn at the next dead ball,
  - The officials will come to the table to sort out the problem.



**NCAA Timer  
Directions**



**NFHS Timer  
Directions**



**NCAA Scorer  
Directions**



**NFHS Scorer  
Directions**

## PRE-GAME RESPONSIBILITIES (CONT.)

### Preparation with coaches:

- **If you don't know who the head coach of a team is, ask one of the players.**
- **All officials, if possible, should meet with the home coach on the field and:**
  - The Referee will ask the coach “Do you certify all of your players are legally equipped by rule?”
  - Get the numbers of the team captains.
  - Get the number of the “in-home,” who must be a starting attack and listed first in the score book.
  - Ask whether he will have ball boys (who must have helmets and who may not wear team colors). If there are no ball boys, be sure the home coach understands that his team is responsible for providing a minimum of four balls just outside each end line to begin each period and for replacing them anytime they become exhausted.
  - Ask if there are any special ground rules concerning the field and if there will be any events affecting the timing of the game (e.g., will they play the national anthem or have a halftime ceremony honoring seniors?).
  - Tell the coach the time you will be calling captains for the coin toss and the time you have on your watch (or, if there is a visible scoreboard clock counting down to game time, tell him at what clock time you will call captains).
- **Next, all officials, should meet with the visiting coach on the field and:**
  - The Referee will ask the coach “Do you certify all of your players are legally equipped by rule?”
  - Get the numbers of the team captains (circle the number of the speaking captain).
  - Get the number of the “in-home,” who must be a starting attack and listed first in the score book.
  - Communicate any ground rules or timing information obtained from the home coach.
  - Tell the coach the time you will be calling captains for the coin toss and the time you have on your watch (or, if there is a visible scoreboard clock counting down to game time, tell him at what clock time you will call captains).



*Coaches  
Certification Cards*



*Pre-game  
Responsibilities  
Video*

### NOTES

---

---

---

---

---

---

---

---

---

---

---

---

---

---

---

---

---

---

---

---

---

---

---

---

**NOTES**

---

---

---

---

---

---

---

---

---

---

---

---

---

---

---

---

---

---

---

---

---

---

---

---

**COIN TOSS**

Five to ten minutes before the scheduled start time, the referee moves to the corner of the home team’s attack area and calls for captains, and the umpire does the same with the visiting team. Neither official should use their whistle yet (whistles should not be used until bringing teams on to the field for the line-up).

At the center, the **home team faces the table area** and the visiting captains face away. The officials face each other and stand to the sides of both teams’ captains.

The **referee** speaks to the captains:

- He introduces himself and the umpire.
- He asks the captains to introduce themselves to each other.
- He explains any special ground rules for the game before the coin toss.
- He presents a coin (at least the size of a half-dollar) and shows each captain which side is heads and which side is tails.
- He explains that he will flip the coin and catch it (without turning it over after it is caught) and that if the coin is dropped it will be flipped again.
- He asks the visiting captain to select “heads” or “tails” before he flips the coin, and the umpire repeats the selection out loud.
- The coin is tossed and caught with an open palm.
- The team that wins the toss shall receive choice of which goal to defend or control of the first alternate possession. The referee has the captains turn and face the goal they will be attacking.
- The referee then directs the captains to return to their benches and tell their teams:
  - Be prepared to begin the game in approximately 2 minutes.
  - When the teams take the field, to line-up with the goalkeeper positioned so that his left shoulder is to the goal he is defending. The rest of the team lines up next to the goalkeeper in the order defense, then midfield, then attack.

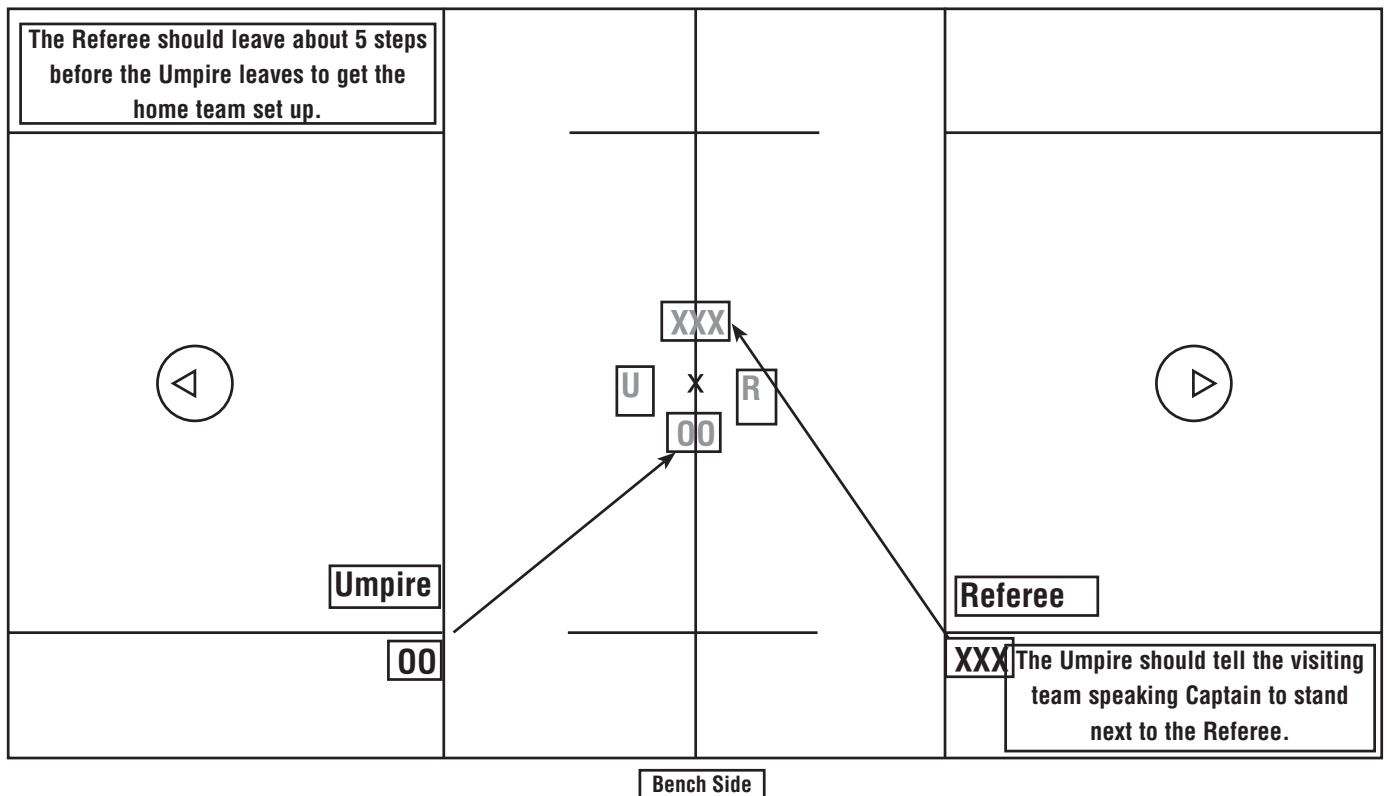

## PRE-GAME LINE-UP

For the line-up, the Referee has the game ball and stands at approximately midfield, facing the goal to the right of the table area. The Umpire faces the Referee in a “mirror” position on the other half of the field.

The Referee sounds the whistle, signaling both teams to come to the center.

As the players approach, the officials help direct the players to their proper line-up positions. It is best to begin with the goalkeepers and then the field players in order. The goalkeeper stands with left shoulder nearest goal he is defending.

Once set, the referee introduces himself and the umpire and says any necessary introductory words of greeting or caution (e.g., warnings about field conditions). These remarks should be as brief as possible.

This is a perfect time to make sure that all players are properly equipped according to the rules for the specific age group, especially the goalkeepers, one of whom will be standing just to your right (always be sure to check goalkeepers for throat guards and chest protectors). Also ensure each team’s in-home player is in the line-up.

The referee instructs the goalkeepers to come together and shake hands.

Once the goalkeepers are out of the way, the referee instructs all other players to shake hands and then move to their positions.

The umpire goes to his spot for the opening face-off. He immediately holds one hand up in the air signaling “wait” while he counts the players on both teams and make sure all is ready for the opening face-off. When certain all is ready, he gives the “ready” signal by dropping his hand and pointing in the direction of the goal he will cover.

When the referee gets the “ready” signal, he conducts the face-off.

## NOTES

---

---

---

---

---

---

---

---

---

---

---

---

---

---

---

---

---

---

---

---

---

---

---

---

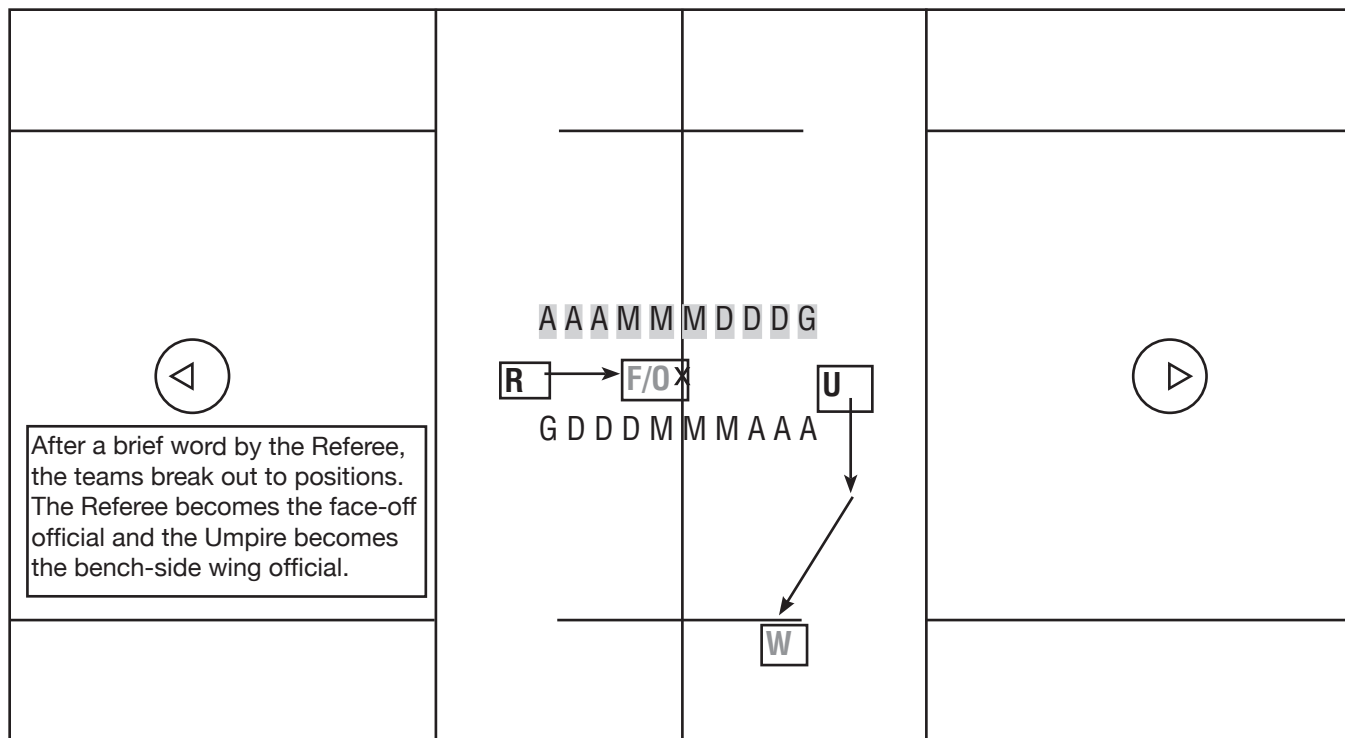

Bench Side

**NOTES****FACE-OFFS**

If a face-off is to begin the quarter, the non-bench-side official conducts it. If the face-off is after a goal, the official who was the Trail conducts it.

**The official at the face-off:**

- Places ball on the ground at the center of the field and stands over the ball.
- Writes the number of the goal scorer on the scorecard (if there's a goal)
- Looks to his partner for the "ready" signal.
- Makes sure the players at center have their backs to their goalie.
- Has players approach ball simultaneously by saying "down."
- Visually checks that both players have:
  - Their hands around their shafts.
  - All fingers touching the ground.
  - Their hands off the head of the stick.
  - Their sticks parallel to center line.
  - The heads of their sticks vertical.
  - Their sticks are up to but not touching the midfield line.
  - Their sticks are evenly matched with the ball centered between the heads.
  - Their entire bodies to the left of the throats of their sticks, so the neutral zone is clear.
- The official stands with the whistle in his mouth and both hands on his sides or on his knees.
- Gives the "set" command when both officials and players are settled.
- Sounds his whistle and backs away to his side of the field while keeping concentration on the face-off.
- Winds the arm and yells "possession" or the color of the team that gains possession. If possession is gained (be sure that there is a clear possession; if you release the players and the ball ends up on the ground immediately, you now have a scrum of 12 players fighting for the ball instead of 6).
- Yells "play" and winds the arm if the ball crosses the restraining line, releasing the players.



*Faceoff Mechanics  
Video*

**The wing (non face-off) official:**

- Pumps fist as the ball approaches midfield
- Turns on the 20-second timer when his partner reaches midfield.
- Takes a position on the end of the wing line or as close to midfield as the players on the wing permit.
- Writes the number of the goal scorer on the scorecard (if there's a goal)
- Alerts his partner of any attackmen or defensemen moving up to the wing area in a man-down situation. Communicate the numbers of players who need to remain onside (e.g., "Blue 31 is hot!") and position yourself to have undisputed view of any offside violations.
- Gives his partner the "wait" signal while counting the players on the field.
- Gives his partner the "ready" signal (by pointing in the direction of the goal the wing official will cover) when player count and positioning is correct.
- Turns off his 20-second timer when all the players are positioned properly for the face-off.
- Watch for wing middies leaving too soon; concentrate on your side of the field.
- Watch for wing middies contacting face-off players illegally.
- Yells "Possession!" or the color of the team that gains possession,
- Winds the arm when possession is gained.
- Yells "Play!" and winds the arm if the ball crosses the restraining line prior to possession.



**Face-off: ball goes away from the face-off official**

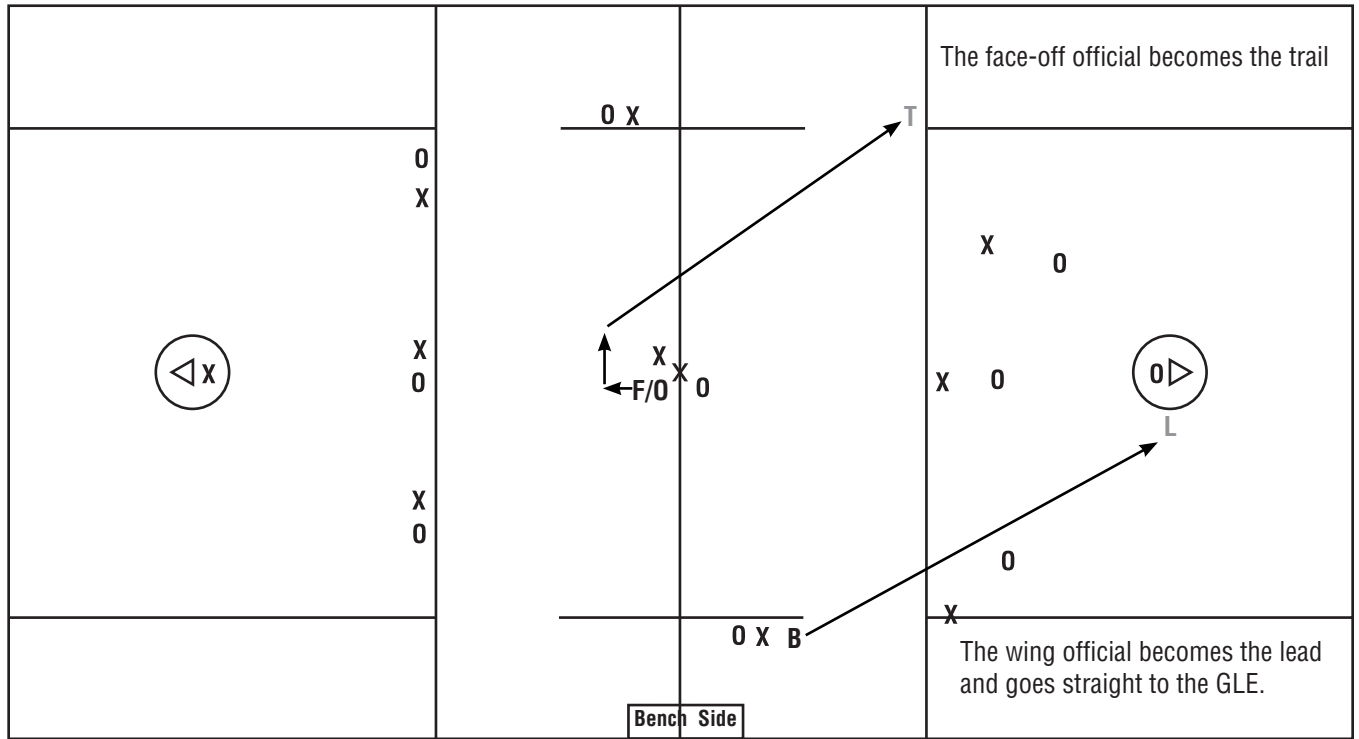

**Face-Off: ball comes toward the face-off official**

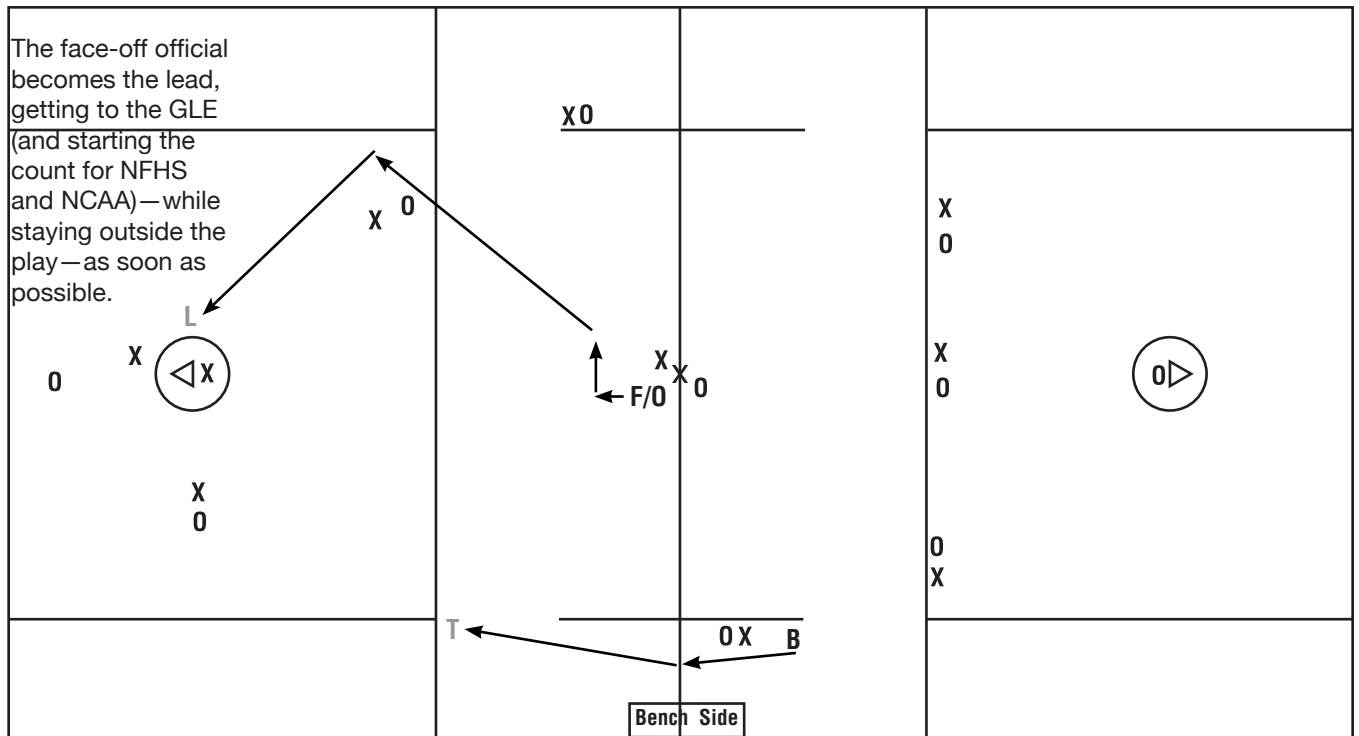

**NOTES**

**SETTLED SITUATIONS**

The shaded areas of the diagram indicate the officials' areas of responsibility for watching the on-ball action in a settled offensive situation. The "on" official is generally responsible for calling fouls such as holds, pushes, slashes, and illegal body checks committed against the player in possession as well as offensive fouls such as warding and withholding the ball from play. The "on" official usually has a narrow focus on the player with possession and the surrounding 5 yards.

The official without ball coverage is focusing attention on the area in front of the crease and on cutters. The "off" official is generally looking for fouls such as late hits, illegal offensive screens, interference, and crease violations, which tend to occur away from the ball.

Both officials must pay constant attention to their positioning so they can avoid turning their backs to the goal and the play, and they must always be aware of who the "on" official is, who the "off" official is, and when it is likely to change. If there is any doubt, communicate who is the "on" and who is the "off" verbally or by pointing. In a settled situation, there should normally only be one flag for a foul.

**The Lead official:**

- Has the goal as the primary responsibility.
- Should try not to move off the goal line extended unless there is a contested play near the end line or unless he must move to get a better angle on the play.
- Should be as close to the crease as possible without interfering with play and without allowing players to get behind him.
- Should be in position relative to the ball and strive to be in good position to call a close play in the crease.
- Has end line responsibility on any shot (chase shots to the end line!).

**The Trail official:**

- Doesn't signal the goal unless absolutely necessary.
- Watches crease area for violations.
- Helps with crease violations on a tight play.
- Is responsible for watching for late hits after the shot.

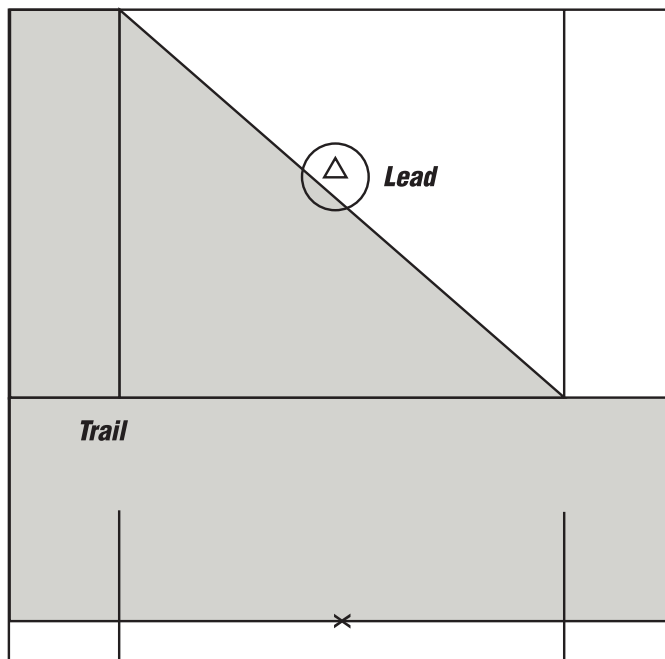

**Note: Pre-game should be clear on how On-Off calls will be communicated.**

## STOPPING AND STARTING PLAY

### NOTES

#### To stop play:

- Each official is responsible for blowing the whistle if the ball (or the player in possession) goes out of bounds on his end line or sideline.
- When there is a play-on, the official calling the play-on is responsible for blowing the whistle to stop play if necessary.
- For a foul by the offense, the official witnessing the foul blows the whistle to stop play.
- When there is a flag down, any official noticing a condition for ending the slow-whistle situation blows the whistle to stop play.
- When the horn sounds to end a period, both officials should blow their whistles.
- When a goal is scored, only the Lead should blow the whistle (unless the Lead does not see the goal and the Trail does).

#### To start a free play:

- On any restart, if the goalkeeper is out of the crease, allow him 5 seconds to get back into the crease.
- Make sure that the player in possession is standing on the field, at least one yard in from the sideline or 5 yards in from the sideline if he is within 10 yards of the midline.
- Be certain that no player from either team is within 5 yards of the player in possession. If someone is too close, call their number and tell them to move back; if they do not immediately comply, continue warning them while doing a 5-second visual count. If they are still too close at the end of 5 seconds, do not start the play; instead, assess a 30-second illegal procedure penalty.
- If the ball is leaving the Trail's half of the field, the Trail will always have the whistle to restart play. If the ball is on the opposite side of the field, the Lead should hold one arm up until the player in possession is in bounds and out of the attack area; then the Lead points in the direction of play. The Trail blows the whistle and has the defensive 20-second count (NFHS) or 30-second count (NCAA).
- If the ball is in the offensive end and is:
  - Coming in from the sideline, the official on that sideline restarts play.
  - Starting on the end line in the attack area or in the Lead's alley, the Lead restarts play.
  - Starting in the Trail's alley, the Trail restarts play.
  - Starting anywhere else, the "on" official restarts play; typically, this means the Lead restarts play in his or her own alley and the Trail restarts play elsewhere.
- Some Referees prefer to have the Lead restart any play on his end line; this should be covered in the pregame.
- The officials should make eye contact before most restarts to make sure they are both ready and—in cases where it is questionable which official should whistle—to determine who is restarting play. If you want the whistle, point to yourself; otherwise, point to your partner.



*Restarting Play  
Video*

*NFHS Rule 4 Sections 6-9, 25, 28 and 29  
NFHS Rule 7 Sections 3, 8 and 10  
NCAA Rule 4 Sections 6-9, 20, 24, 26, 27, 30 and 31  
NCAA Rule 7 Sections 3, 8 and 10*

**NOTES**

**GOAL SCORED AND READYING THE BALL FOR FACEOFF AFTER GOAL**

**The lead official:**

- Sounds the whistle immediately upon realizing the entire ball has passed beyond the goal line,
- Turns to face “action” in front of the goal, and gives the goal signal while stationary (2–3 seconds),
- Retrieves the ball from the goal, (Do not ask the goalie to get the ball out of the net for you)
- Tosses or hands the ball to his or her partner at the center of the defensive area line,
- Takes a position near the wing line on the correct side of the field
- Notes the number of the player scoring the goal on the scorecard,
- Conducts face-off duties as discussed earlier in this manual.

**The trail official:**

- Waits for a whistle and goal signal by the Lead,
- Watches the crease for fouls/late hits,
- Moves toward the high crease,
- Goes to retrieve the ball from his partner at or under the restraining line” and watch action in front of the crease,
- Secures the ball from his partner and runs to the center of the field,
- Steps over midfield and turns around to face his partner (and the end of the field where the goal was just scored),
- Places the ball on the ground and straddles it while he writes the number of the player scoring the goal on the scorecard,
- Conducts face-off duties as discussed earlier in this manual.



*Goal Scored and Faceoff Mechanics Video*

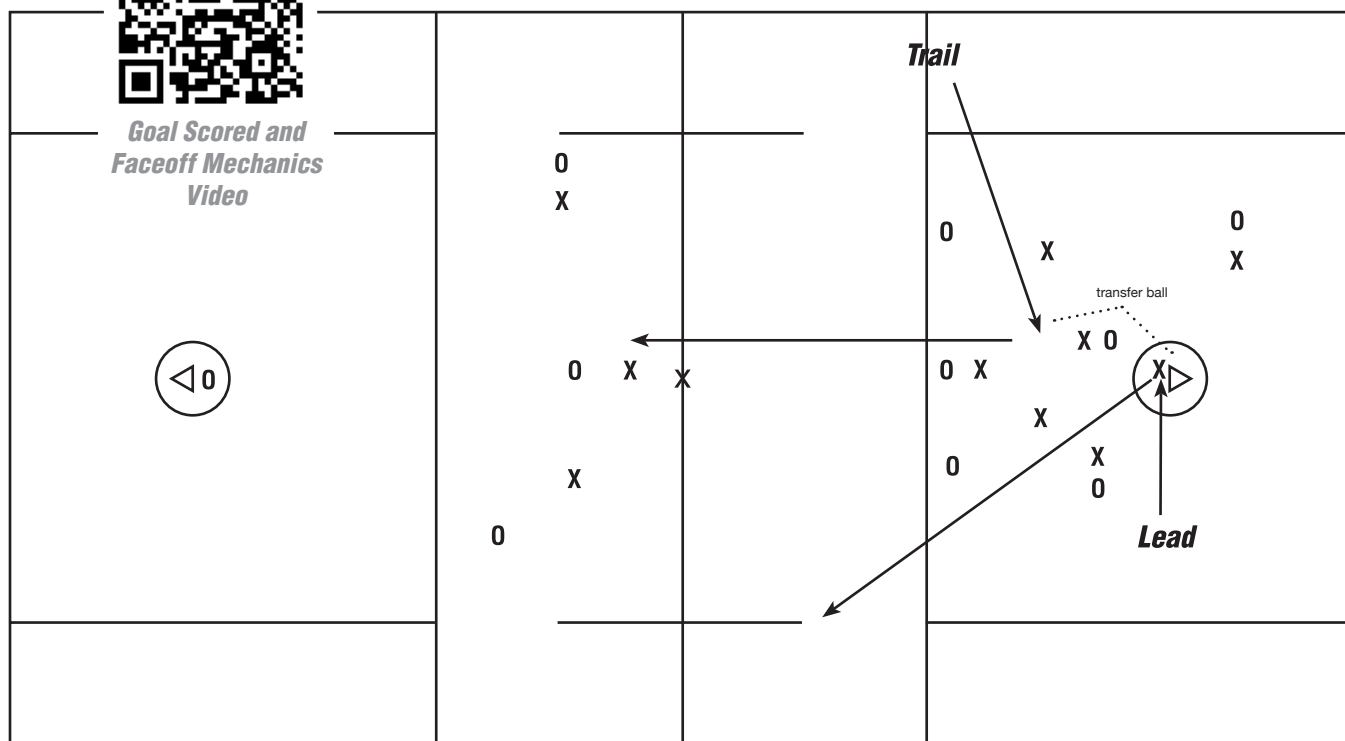



**NOTES**

**DEEP RESTART WITH THE BALL ON THE TRAIL OFFICIAL'S SIDE**

In the event of a non-time-serving foul in the attack area that awards possession to the defense (e.g., a ward, an offensive crease violation, a loose-ball technical foul), move the ball to the nearest alley because this will make it easier for the Trail to follow the play.

**The Trail:**

- Restarts the play and is positioned according to his expectations of the play on the ball (e.g., where the play is likely to be contested).
- Moves up field with—not ahead of—the ball.
- Has offside responsibility on the vacated half of the field as the ball moves across midfield.
- Must maintain visual communication with the Lead (use hand signals).

**The Lead:**

- Has the primary responsibility of covering his goal.
- Sets an initial position based on a variety of factors (e.g. the game situation, the teams' tendencies, the players' skills, his own mobility), but he will normally start no farther from his own goal than midfield.
- Is responsible for the "quick offside" call (i.e., any offside violation made by the players from the Lead's half of the field, the side to the Lead's right).
- Must be prepared to "hold" the center line and count offside on the clearing team's defensive half of the field if the Trail is caught with a contested play on his side of the field.
- Must cover his goal on a long pass.
- Must maintain visual communication with the Trail (use hand signals).
- Signal ready when the field is ready.

**Note:** The above mechanic is also used when the ball goes out of bounds on the sideline and is awarded to the defense.

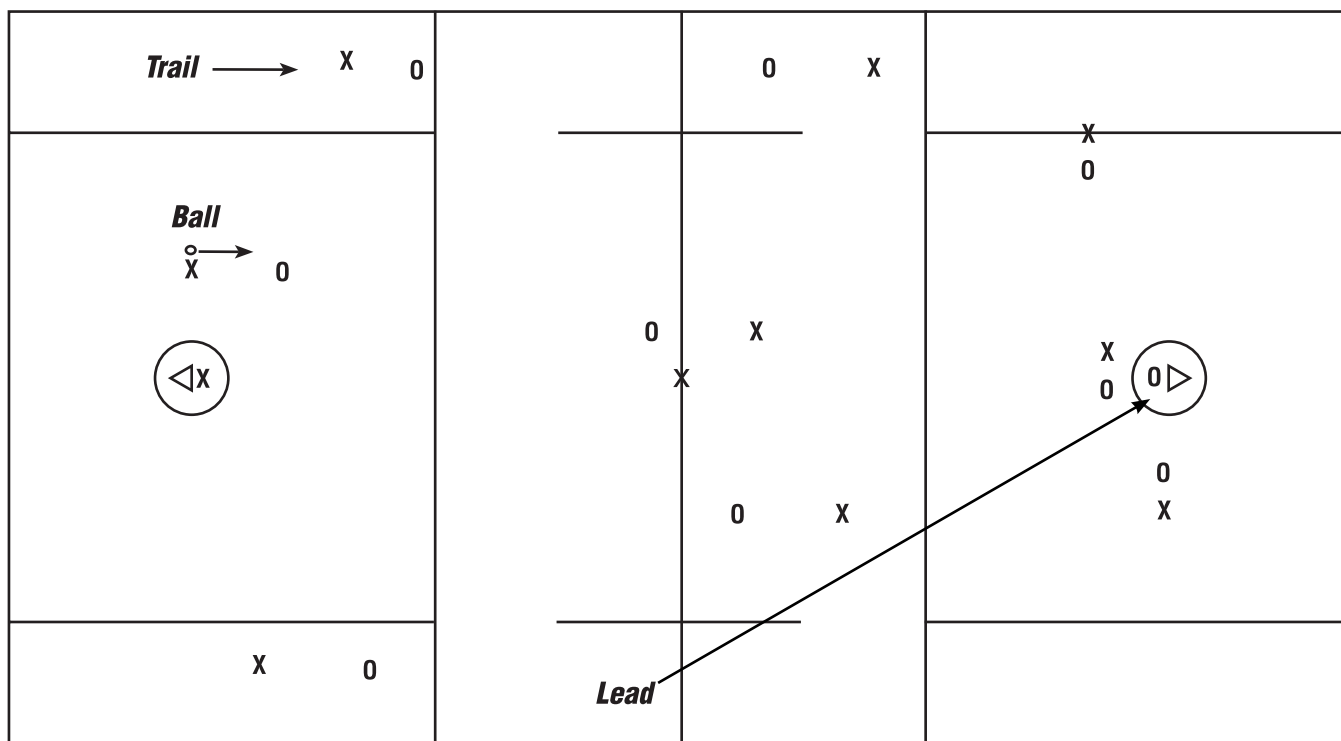

## DEEP RESTART WITH THE BALL ON THE LEAD OFFICIAL'S SIDE

The proper mechanics depend heavily on the age, tendencies, and skills of the players in the game. The Trail official may need to move across the field an appropriate distance to cover a contested restart but should stay on his side of the goal.

The new Lead should keep one hand up until a clearing-team players has possession and is in the alley (i.e., neither out of bounds nor in the attack area) since the Trail will likely not be able to see the far sideline. As soon as the player is ready, the Lead should point in the direction of the play and the Trail should blow the whistle.

Once the play has been restarted by the Trail, he should release the player with the ball to the Lead as soon as he determines that the player is in the Lead's coverage. Once released by the Trail, the player with the ball becomes the responsibility of the Lead and the coverage of the clear takes place in a normal fashion.

### NOTES

---

---

---

---

---

---

---

---

---

---

---

---

---

---

---

---

---

---

---

---

---

---

---

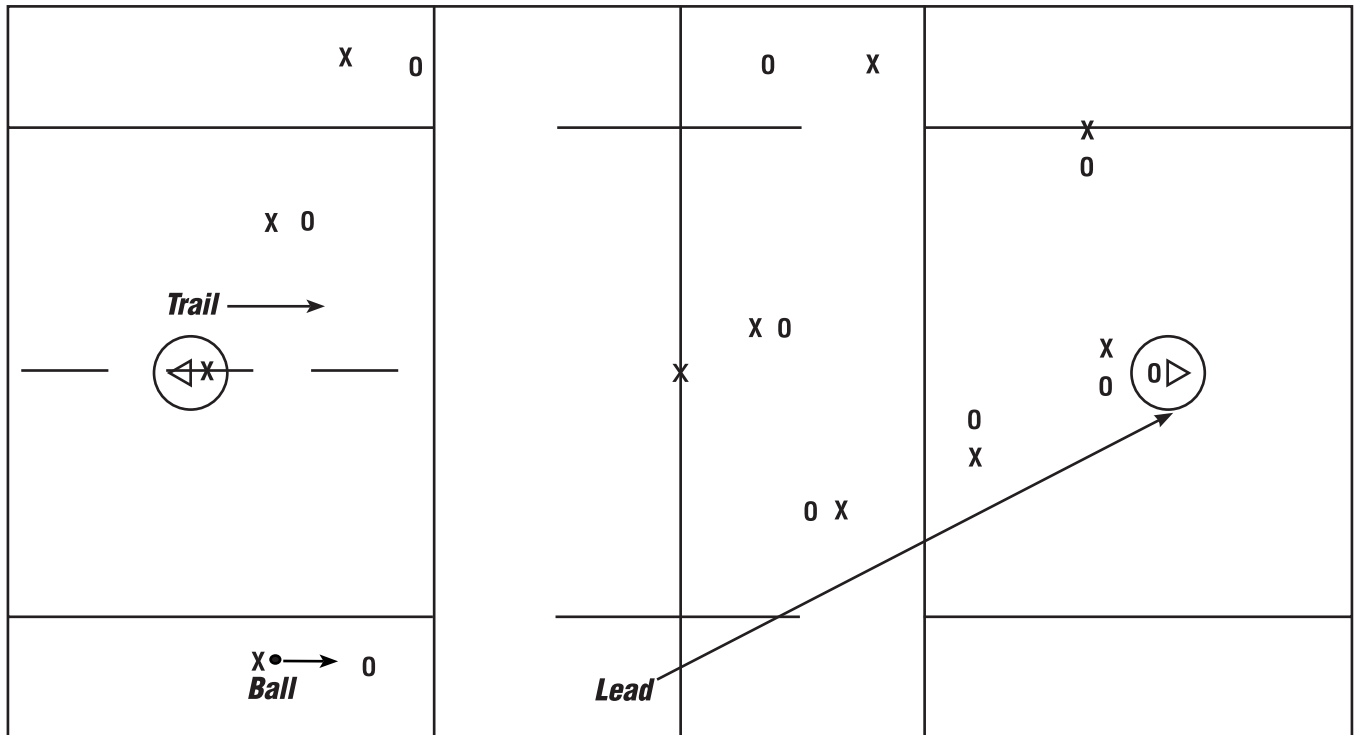

**NOTES****PENALTY ENFORCEMENT**

**Once you have determined that a foul has been committed, you must determine which of the following situations you are in:**

- For loose-ball technical fouls (and also for most goalkeeper interference and crease violation fouls even if the ball is not loose), you will either employ the play-on technique or whistle immediately.
- For a foul by Team B when Team A has the ball, yell “Flag down” and throw your flag straight into the air without blowing your whistle. Team A will have a chance to complete the scoring opportunity. Play stops when Team A scores a goal or when the rules require the official to whistle and stop play.
- For a foul by the team in possession, or for any loose-ball personal foul, blow your whistle immediately.

**Once you sound the whistle, you should:**

- Make sure the play is completed, including any dead-ball residue.
- Gather your thoughts.
- Check for flags from your partner. If there are multiple flags, determine if you have two flags for the same foul or flags for two different fouls.
- Position yourself promptly but not hastily:
  - Report foul # and type to your partner and the field
  - Facing the table with an unobstructed view of the table
  - Be tall and stationary.
- Signal the penalty – always use ‘C-NOTE’
  - Color, Number, Offense, Time, Explanation (If Necessary)

Live ball fouls are ones committed during the play of the game. There are five possible scenarios, since there are both personal and technical fouls that can be committed during possession by either team or during a loose ball.

**Personal and Technical fouls with possession by the team that was fouled:**

- Throw the flag straight up into the air
- Yell “Flag down” AND allow the offensive team (with possession) to complete their play,
- Sound your whistle to stop play when the rules require you to do so,
- Make certain all residual action among the players has ceased,
- Report foul number and type to your partner and the field,
- Announce foul, signal infraction, start play.

**Technical fouls during a loose ball:**

- Use the “play-on” mechanic if appropriate,
- Sound your whistle to stop play if necessary,
  - Keep the play-on short. If no immediate advantage or disadvantage you should stop the play immediately
- Make certain all residual action among the players has ceased,
- Announce foul, signal infraction, restart play.

**Technical fouls with possession by the team committing the foul:**

- Sound your whistle to stop play and make certain all residual action has ceased,
- Announce foul, signal infraction, restart play.

**Personal fouls during a loose ball and personal fouls by the team in possession:**

- Throw the flag straight up into the air
- Sound your whistle immediately to stop play,
- Make certain all residual action among the players has ceased,
- Report foul number and type to your partner and the field,
- Announce foul, signal infraction, restart play.



*Penalty Relay Video*



## PLAY ON

## NOTES

### Enforcement after a slow whistle:

- **A player that has committed a personal foul will always be suspended from the game whether or not a goal was scored during the slow whistle.**
- **A player that has committed a technical foul will not be suspended from the game if a goal was scored during the slow whistle.**

### Play-on technique

If a player commits a loose-ball technical foul or crease violation and the offended player’s team may be disadvantaged by the immediate suspension of play, the official shall visually and verbally signal “Play-on.” The whistle shall be withheld until the play ends or advantage is gained or lost.

The play-on is intended to allow the game to flow. It makes no sense to stop the game for a loose-ball technical foul and then award possession to the team that would have gained possession anyway. This is particularly true if the team that was fouled had an opportunity to start a fast break. When the ball is loose outside the crease:

- **If one team has an opportunity to gain a clean possession and the other team commits a technical foul, use the play-on technique.**
- **If one team is about to gain possession and the other team commits a technical foul or line violation, but the team gaining possession would quickly be disadvantaged by going out of bounds or being trapped by opposing players, sound an immediate whistle.**

### Enforcement of play-on

The play-on technique allows play to continue if the fouled team is not disadvantaged by the foul; this improves the flow of the game by reducing the number of stoppages. The play-on technique should only be used when it is advantageous to the team that was fouled.

When a play-on is appropriate for a loose-ball foul (and some crease violations and goalkeeper interference penalties with possession), the official shall raise one hand overhead and yell “Play on!” For a typical loose-ball foul, the whistle will be withheld until:

- **Several seconds pass with neither team gaining possession.**
- **The team that committed the foul gains possession.**
- **The team that was initially fouled commits a foul.**
- **Any other action occurs that requires the officials to blow the whistle.**

Once the whistle is blown, the officials signal the loose-ball foul and award possession to the team that was fouled to begin the play-on. However, if the fouled team is able to gain possession, the play-on is over and play continues without a stoppage. When this happens, the official should drop the raised arm, and point in the direction of the play and simultaneously verbally state “play-on over” so that everyone knows the play-on situation is over.

---

---

---

---

---

---

---

---

---

---

---

---

---

---

---

---

---

---

---

---

---

---

---

---

## MAKING THE DECISION: WHISTLE, FLAG DOWN, OR PLAY ON?

	<b>Technical Foul</b>	<b>Personal Foul</b>
<b>Loose ball foul by B1</b>	<b>Play on</b> only if Team A would be disadvantaged by a stoppage of play (otherwise immediate whistle). If Team A gains possession, the play-on ends and play continues. If Team A doesn't gain possession within a few seconds, blow the whistle and award possession to Team A. (See note below.)	<b>Immediate whistle</b> and flag. B1 serves a 1- to 3-minute penalty. Team A is awarded possession (and, if necessary, a free clear).
<b>Team A has possession, foul by B1</b>	<b>Flag down, slow whistle.</b> Allow play continue until one of the conditions for ending a slow whistle is met. If Team A scores, B1 serves no penalty time and there is a face-off; otherwise, B1 serves 30 seconds and Team A gets possession (and, if necessary, a free clear).	<b>Flag down, slow whistle.</b> Allow play continue until one of the conditions for ending a slow whistle is met. B1 serves a 1- to 3-minute penalty. If Team A scores a goal, there is a face-off; otherwise, Team A gets possession (and, if necessary, a free clear).
<b>Team A has possession, foul by A1</b>	<b>Immediate whistle</b> and award possession to Team B.	<b>Immediate whistle</b> and flag. A1 serves a 1- to 3-minute penalty. Team B is awarded possession (and, if necessary, a free clear).

**Note:** If you are a Level 1 official and you are not yet comfortable with the "play-on" technique, the "play-on" violation above can be handled with an immediate whistle.



*Fouls Decision Tree*

## EQUIPMENT CHECKS

Whether a check is being conducted at the request of the opposing coach or as a result of a routine inspection, the crosse inspection procedure is identical. Both must be done during a dead-ball situation. You must always verify all aspects of the player's equipment and crosse if the coach requests an inspection.

## NOTES

- Go to the player whose crosse you've been requested to, or have decided to check. Identify him by number and ask for his crosse.
- He may not touch the strings or jam the head once you have requested his crosse. If he seems about to do either, caution him not to; if he does so anyway, assess a 1-minute non-releasable unsportsmanlike conduct penalty and continue with the inspection.
- Any attempt by the goal scorer to adjust the pocket depth using a drawstring after a goal will be penalized with a 1-minute unsportsmanlike conduct penalty and the goal will be disallowed, even if the adjustment occurs before the official asks for the crosse.
- For coach requested checks (and for routine checks under NFHS rules), quickly check to make sure the player has a legal mouth guard, shoulder pads, arm pads, gloves (palms and fingers cannot be cut out), helmet, and cleats. If any required gear is illegal or missing, he receives a 1-minute non-releasable personal foul penalty.
- Take the crosse and move away from the player being inspected.
- Use the game ball to check the first two aspects of the crosse:
  - Place (don't jam) the ball into the pocket and hold the crosse parallel to the ground at eye level. If you can see the top of the ball beneath the bottom of the sidewall, the pocket is illegal
  - Again, place the ball into the pocket and rotate the crosse slowly forward from a vertical orientation to verify the ball freely rolls out of the crosse.
- Next, use your tape measure to check the measurements:
  - Measure the total length of the crosse along the handle from end of the stick to the very end of the head.
  - Measure the inside edges of the head at its widest point.
  - Measure the length of the inside of the head from plastic to plastic.

---

---

---

---

---

---

---

---

---

---

---

---

---

---

---

---

---

---

---

---

---

---

---

---

---

---

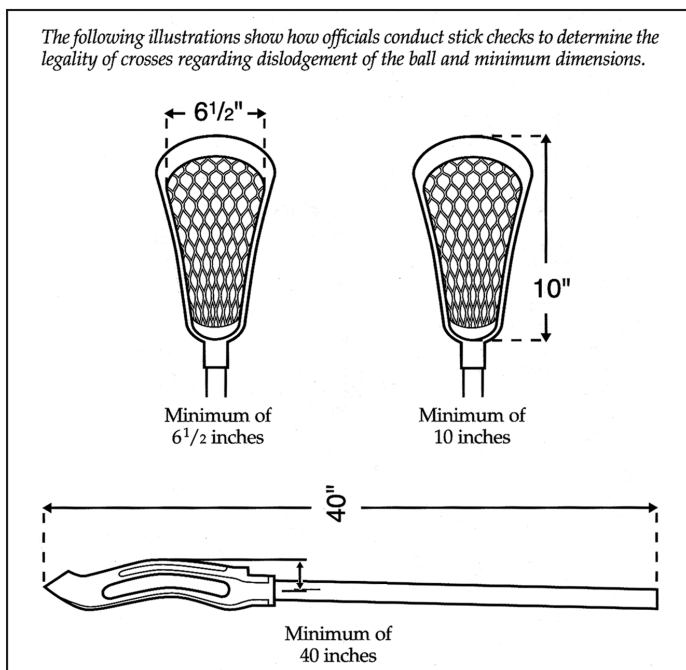
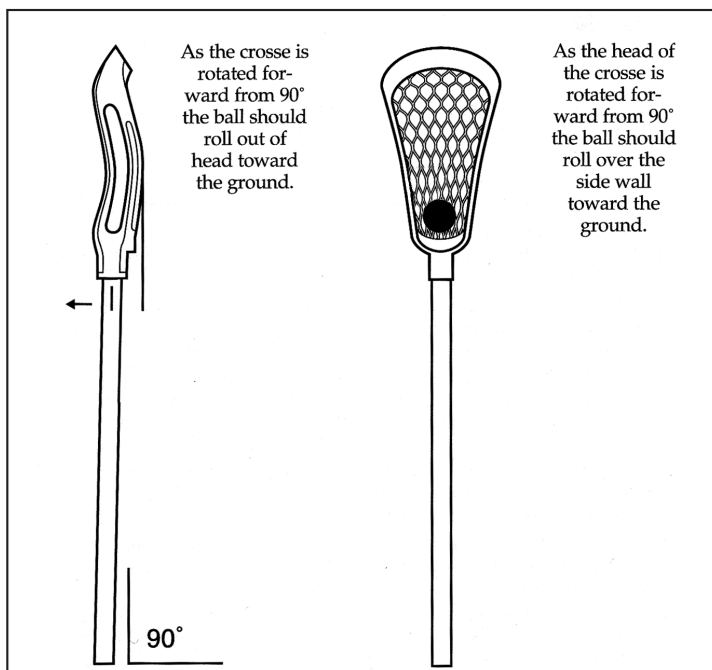

**NOTES**

**EQUIPMENT CHECKS (CONT.)**

- **A crosse with an illegally deep pocket is penalized 1 minute (non-releasable) and may reenter the game if corrected; this is essentially the only crosse violation for which the penalty is 1 minute and for which the crosse may return.**
- **A crosse penalized for any other reason detailed here remains at the table for the remainder of the game and receives a 3-minute non-releasable penalty.**
- **Be sure that the crosse is really illegal before penalizing it; if you aren't sure, err on the side of not penalizing it.**
- **Report the foul to the table and explain what the violation was.**
- **A broken crosse does not draw an illegal crosse penalty. However, someone playing with a broken crosse is guilty of an illegal procedure technical foul.**

As previously mentioned, equipment checks are to be done during dead ball situations, such as:

- **During a team time-out,**
- **After a goal,**
- **Before a face-off,**
- **Between periods.**

These checks should be done so they have a minimal impact on the flow of the game.

Different areas have different policies on equipment checks, so be sure to check with your trainer to find out the local procedures. In particular, be certain to find out whether you are expected to conduct inspections in local youth lacrosse contests.

One equipment check plan that works well is to do two checks per team in the first half after goals, then do one check per team in the second half at some time other than after a goal. When you check after a goal is scored, normally the trail official will grab the goal scorer's stick and the lead will grab a long pole from the defending team, but that may change depending on circumstances (e.g., on the position of the goal scorer). The lead will get the ball from the goal and check for pocket depth and rollout while the other official measures. The lead then transfers the ball to the other official and they both complete their check. Under NFHS rules, the other equipment must be inspected as well.

Note that if the goal-scorer's crosse is discovered to be illegal after a goal and before play restarts, the goal is disallowed. Other illegal equipment, however, does not disallow the goal.

## **EQUIPMENT CHECKS (CONT.)**

### **Some other key points regarding equipment checks:**

- In order to keep the game moving, practice until you can complete a stick check in under 30 seconds.
- A good rule of thumb is that if it takes you more than 5 seconds to complete any aspect of the test because the stick is borderline, move on to the next part of the inspection; if it's that hard to determine legality, give it the benefit of the doubt and assume it is legal.
- To speed the measurement of long poles, determine points on your body that corresponds to heights of roughly 52 inches and 72 inches (or, if you are shorter than that, how far above your head the point is); since the crossbar of the goal is 72 inches above the ground, you can also use that as a benchmark.
- When checking the stick, test the pocket depth, ball rollout from the throat and both sides, the head width from the front, the head length, and the stick length. The back of the head is not to be measured, and we do not check to determine if the ball lodges in the back of the head of the crosse.
- Be sure to complete all required checks before the 5-minute mark of the fourth period.
- It is not necessary to keep track of the numbers of the players inspected; writing the numbers down on your scorecard takes too much time. It is fine if the same player gets checked twice in one game. On the other hand, try to have some idea who has been inspected so you don't inspect the same player 3 or more times in the same game.
- Never check a goalkeeper stick unless the opposing coach requests it.
- If you have trouble remembering all of the measurements, tape them onto your tape measure.
- Random equipment checks should not be done during a flag-down situation or when someone is already serving a time serving foul.

## **NOTES**

---

**NOTES**

**TIME OUTS**

**Official Timeouts**

- An official may suspend play at any time at his discretion for any reason he deems necessary for the proper enforcement of the rules or conduct of the game including issues with the players, coaches, spectators, table, field or weather. The Referee should notify the other officials, table and both coaches as to the reason for the game stoppage.
- Loss of Equipment – the official will stop play and allow the offensive player to fix the equipment issue and re-start outside the attack box. If the player is behind the ball, the player can fix the equipment issue or substitute for another player that is fully equipped.
- Injured player – the official will stop play if the injured player is in the play or in the attack area. If the official deems the injury to be serious, he will stop play immediately. The official closest to the player should approach, but should not touch or assist the player. The official nearest the bench should notify the coaching staff/trainer. If the uniform has blood on it that cannot be removed, he may change numbers as long as the table and other team are notified. An official timeout due to a player injury will not be charged a timeout.
- Concussions – any player who exhibits signs, symptoms or behaviors consistent with a concussion (such as loss of consciousness, headache, dizziness, confusion or balance problems) shall be immediately removed from the game and shall not return to play until cleared by an appropriate health-care professional. Also note the NFHS Suggested Guidelines for Management of Concussion, in Appendix B of the NFHS Rule Book.
- Mistakes by an official should be corrected as quickly as possible. The Referee should correct the mistake, notify the table and coaches. The Referee must also allow or disallow the goal depending on the circumstances.
- If a player, coach, spectator or any other person is ejected from the game and needs to be removed from the premises. The Referee will be in contact with the Game Administrator and, if necessary, security and/ or law enforcement. The other official will monitor the field and have the ball ready for restart.

**Team/Player Timeouts**

- During play, a timeout may be called by a team on the field or head coach when they are in possession of the ball anywhere on the field (NFHS), when in possession across the offensive restraining line (NCAA) or if there is a dead ball. The official nearest the person calling the timeout should stop play and the trail official should notify the table and start his timer. The bench official should be positioned near the substitution box to prevent any player issues while the other official is getting the ball ready for play. The official should then confer with the table to verify the remaining timeouts for the teams and confirm with the other official.
- At 1 minute and 40 seconds, the bench official should whistle for the teams to return to the field and start the timer.
- Coaches and teams should remain in their respective coaching areas and not come onto the field during the timeout.
- Each team is allowed one illegal equipment request per game and will not be charged a team timeout; if the equipment is found to be illegal which also allows the team to have another illegal equipment check during the game or if the illegal equipment check is found to be legal the first equipment check.
- Each team can call for a double horn at a dead ball situation and request a count of the long poles on the field. If the head coach makes a second request where the long poles were correct, the team is penalized.

*NFHS Rule 4 Sections 27-29; Rule 7 Section 13  
 NCAA Rule 4 Sections 26 and 27; Rule 7 Section 12*









**NOTES****POST-GAME****Debriefing, Lessons Learned and Improving Your Game**

Officials can't learn from mistakes unless mistakes are made. You will make plenty of them as you learn how to officiate the game. The trick is not to repeat them. But because mistakes are a part of the game, you will want to learn as much as you can from these errors. Post-game analysis is often difficult to conduct immediately after the game, when people have to get back to their families or other obligations. Some suggestions:

- **You can control the kind and the amount of feedback that you get by the way that you react to the information that you've requested. If you request feedback, be open to it and listen to what is said rather than challenge the people who you ask to assist you.**
- **Rather than just asking how you did, ask specific questions. Here is a sample dialogue: "Do you remember that illegal body check call that I had in the third quarter? What did you have? Tell me why you would or wouldn't have made that call."**
- **Propose going somewhere to buy your officiating partner a soda, even if it is to a gas station on the way out of town. Then you can take a few minutes to clear the air regarding the game.**
- **Ask permission to call your officiating partner at night to discuss.**
- **If you have a mentor, be sure to check in with this senior official for feedback.**
- **Keep reading the rule book, focusing on Rules 4, 5, and 6 (and also the "play on" and "slow whistle" portions of rule 7). As you do this, you'll continually find situations that you saw in your games and didn't know how to handle. Be sure to read the situations in the rule books as well as the rules themselves.**
- **Continue your officiating education regularly through your local officiating organization and practice, practice, practice!**



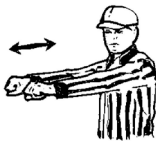



## ARM SIGNALS

DIAGRAM	OFFICIAL'S MOTIONS	PERSONAL FOULS
	<p><b>PERSONAL FOULS</b> Personal fouls are those of a serious nature and will result in a man advantage. The emphasis on safety and sportsmanship in youth lacrosse is expressed in stricter enforcement of personal fouls. Official points index finger upwards and blows whistle</p>	<p>An offending player's team will be a man down while he serves his penalty in the penalty box. A personal foul can be one, two, or three minutes, depending on the official's judgment of the severity and perceived intent of the foul. Fouled team will be given possession.</p>
	<p><b>ILLEGAL BODY CHECK</b> Elbow is brought horizontal to shoulder with hand on chest and then moved up-and-down NO body checking of any kind permitted in U9 and U11 Take-out checks NOT ALLOWED at any level, ever!</p>	<p>Fouls will be called for a body check:</p> <ul style="list-style-type: none"> <li>• of an opponent without possession of the ball or more than 3 yards from a loose ball.</li> <li>• delivered without 2 hands on the stick</li> <li>• avoidable hit on opponent who's already passed or shot the ball.</li> <li>• to a player from behind, below the waist or above the shoulders, including following through to head.</li> <li>• to a player with any body part other than their feet on the ground.</li> <li>• initiated with the head, also known as spearing and assessed a non-releasable penalty.</li> <li>• considered more aggressive than necessary to knock to the ground, injure the player or made in a reckless or intimidating manner.</li> </ul>
	<p><b>CROSS-CHECK</b> Pushing the arms away from body in a parallel fashion</p>	<p>A player cannot use the stick shaft between his hands to play an opponent, either when thrust against his opponent or striking him while running with his stick extended.</p>
	<p><b>ILLEGAL STICK</b> Pointing toward the illegal stick</p>	<p>A player may not use a stick that doesn't conform to specifications. For example, it is a:</p> <ul style="list-style-type: none"> <li>• 1-minute non-releasable penalty if a stick has too deep a pocket or weaving not firmly attached.</li> <li>• 3-minute non-releasable penalty for any other reason and stick is removed for balance of game.</li> </ul>
	<p><b>ILLEGAL EQUIPMENT</b> Pointing toward the illegal equipment or where it would be on the player</p>	<p>A player may not use equipment that doesn't conform to specifications. For example: cutting palms out of gloves or altering protective equipment like shoulder and arm pads, non-regulation lacrosse helmets and mouth guards, Jewelry, unless religious or medical alert items taped.</p>









## ARM SIGNALS

DIAGRAM	OFFICIAL'S MOTIONS	PERSONAL FOULS
	<p><b>SLASHING</b> Intersecting arms. One arm chopping the other, normally at face height</p>	A poke into the ribs, chest, neck or back. A vicious, uncontrolled swinging the stick, whether contact is made or not. The gloved hand on the stick may be legally checked.
	<p><b>TRIPPING</b> Swinging one arm at knee level</p>	A player may not trip an opponent with a positive action of his body or stick below their waist resulting in their being obstructed.
	<p><b>UNSPORTSMANLIKE CONDUCT</b> Arms extended from shoulder height</p>	<p><b>Non-releasable</b> - arguing with official, using threatening or obscene language or gestures, bating or taunting, or any other act officials deem unsportsmanlike.</p> <p><b>Releasable</b> - repeatedly committing same technical foul, not returning to field immediately, and a substitute deliberately not complying with rules for entering game.</p>
	<p><b>UNNECESSARY ROUGHNESS</b> A salute motion</p>	Any excessively violent infraction of the rules governing holding or pushing. Includes checks delivered with a punching blow, against a player setting a pick or a stationary defender and checking an opponent who is in a vulnerable position.
	<p><b>FOULING OUT</b> No specific signal for foul Whistle with arm straight up or ejection motion often used</p>	A player, substitute, coach or other team personnel can be ejected from the game for serious infractions. See ejection foul page for further details. Ejection fouls are enforced with a three-minute non-releasable penalty.
	<p><b>EJECTION</b> Thumb Up, hand moves up over shoulder</p>	A player, substitute, coach or other team personnel can be ejected from the game for serious infractions. See ejection foul page for further details. Ejection fouls are enforced with a three-minute non-releasable penalty.









## ARM SIGNALS

DIAGRAM	OFFICIAL'S MOTIONS	TECHNICAL FOULS
	<p><b>TECHNICAL FOULS</b>                      Technical fouls are fouls of a less serious nature and include all violations of the rules except those listed as personal or ejection fouls. Signal only if time being served. Arms placed in a "Tee" formation at chest level.</p>	<p>The penalty for a technical foul is either:</p> <ul style="list-style-type: none"> <li>• 30 second releasable penalty after flag-down, slow- whistle if fouled team had possession at the time</li> <li>• Possession awarded to fouled team after play-on ended if it wasn't in possession of the ball</li> <li>• If ball remains loose, fouled team awarded ball at spot of infraction</li> </ul>
	<p><b>CREASE VIOLATIONS</b>                      Sweeping motion of the arm towards the crease</p>	<p>Usually from stepping into the crease while on offense.</p>
	<p><b>HOLDING</b>                      Grasping a wrist with the opposite hand and using a vertical pumping motion</p>	<p>Numerous violations which include holding an opponent with a free hand and holding the body of an opponent with a stick.</p>
	<p><b>ILLEGAL OFFENSIVE SCREENING</b>                      One hand bent at elbow extending up and the other hand moving toward elbow</p>	<p>Teammate moving or stepping into opponent while trying to screen a player guarding a teammate.                      Often referred to as a "moving pick," no offensive player shall move into and make contact with a defensive player with the purpose of blocking a defensive player from the man he is playing.                      Called only when one offensive player checks a defensive player when the checker's team has possession.</p>
	<p><b>PUSHING</b>                      One hand against body and other hand makes a pushing motion away from body</p>	<p>A player shall not thrust or shove an opponent from the rear. Pushing is permitted from the front or side when an opponent has possession of the ball or is within 3 yards of a loose ball.</p>
	<p><b>ILLEGAL PROCEDURE</b>                      Forearms horizontal at chest level rotating around each other</p>	<p>Any number of actions on the part of players or substitutes of a technical nature that are not in conformity with the rules and regulations governing the play of the game shall be termed illegal procedure.</p>











*Animated Signals*

## ARM SIGNALS

DIAGRAM	OFFICIAL'S MOTIONS	TECHNICAL FOULS
	<b>CONDUCT FOUL</b> One arm held extended from body at shoulder height	Aggressively object by arguing or gesturing to a decision by an official.
	<b>INTERFERENCE</b> Hands crossed over the chest	Violations include impeding a player running through the attack area and contact not within 3 yards of a loose ball.  A player shall not interfere in any manner with the free movement of an opponent when his team has possession.
	<b>OFFSIDE</b> Both hands on hips	Too many players in either end of the field.
	<b>STALLING/DELAY OF GAME</b> Hands clasping forearms at stomach level	A stalling violation will be called if the ball leaves the goal area after the stall warning, unless it's from a shot deflected off the goal, goalie or a or a pass that is deflected by a defensive player.
	<b>WARDING OFF</b> Fist near chest while moving elbow up	A player in possession of the ball shall not use his free hand or arm or any other part of his body to hold, push or control the direction of the movement of the crosse or body of the player applying the check.
	<b>WITHHOLDING BALL FROM PLAY</b> Arms extended from body with one hand covering the other	Lying or sitting on a loose ball. Clamping a ball longer than necessary to pick it up.



## ARM SIGNALS

DIAGRAM	OFFICIAL'S MOTIONS	PROCEDURAL FOULS
	<p><b>GOAL SIGNAL</b> Turns toward center of field, arms raised and then lowered.</p>	<p>The goal line official calls all goals. The ball must pass completely through the plane of the back edge of the pipes. Hitting two or three pipes does NOT designate a goal.</p>
	<p><b>NO GOAL</b> Arms extended toward the ground and swung out-and-in so that they cross each other.</p>	<p>Goals that are scored illegally are quickly reversed by the official. Possession is awarded to the defending team.</p>
	<p><b>TIMEOUT</b> Turns towards the timer and crosses fully extended arms at the wrist above the head.</p>	<p>The official will alert the timekeeper when to stop the clock. In games that use running time, certain conditions like legal timeouts, injury timeouts and equipment checks will require the clock to be stopped.</p>
	<p><b>DIRECTION OF POSSESSION</b> Arm is raised horizontally at shoulder level and pointed towards the goal of the team awarded possession</p>	<p>The official will indicate the direction of play when either the ball goes out of bounds or there is a loose ball technical foul that results in a change of possession.</p>
	<p><b>OFFENSIVE STALLING WARNING</b> One hand vertically up and the other arm pointing towards goal</p>	<p>Attacking team is not making an effort to attack the goal and score.</p>
	<p><b>FAILURE TO ADVANCE</b> Hand over head, palm down, with a tapping motion</p>	<p>Failure to advance the ball over the midfield line in 20 seconds or to bring the ball into the goal area within 10 seconds after crossing the midfield line can result in a turnover.</p>
	<p><b>LOOSE BALL</b> Two hands pointing down at the ground</p>	<p>Indicates that the ball was loose when there was a technical foul.</p>
	<p><b>PLAY-ON</b> One hand extended above shoulder into the air</p>	<p>If a player commits a loose-ball or line violation foul, goalie interference or crease violation and the offended player may be disadvantaged by the immediate suspension of play, the official will delay the whistle and signal play-on.</p>



*Animated Signals*



US LACROSSE  
OFFICIALS  
EDUCATION  
PROGRAM

**GAME MANAGEMENT  
LEVEL 2**

## GAME MANAGEMENT

“Game management” refers to the collection of techniques used to ensure that the game runs smoothly. Newer officials typically have to work hard just to correctly execute the “science” of lacrosse officiating: remembering all of the appropriate rules, judging the game correctly, and following the correct mechanics. Officials with a bit more experience can start to focus on the “art” of lacrosse officiating: keeping the game flowing, communicating appropriately, and preventing problems before they occur. This section is designed to help you learn some of the key aspects of game management.

### GAME MANAGEMENT 1: PRE-GAME

What you do in the twenty minutes before the game can have a tremendous impact on your game management. Showing up to the field with plenty of time to spare in a neat, clean uniform, carrying yourself professionally as you inspect the field, introduce yourself to the coaches, and conduct your coach’s certifications all create the feeling that you know what you’re doing. The coaches come to expect this routine, and if you deviate from it, they will start out questioning your abilities before you make a single call.

It is also important to establish a rapport with the table personnel. Give them as much information and instruction as they can handle, because a smooth-operating table area goes a long way in game management. There are printed guidelines for timers and scorers available on the US Lacrosse web site which serve as a “cheat sheet” to help them stay on track; giving these to the table personnel often helps. In any case, make sure they know to call you over if they are unsure about anything.

Take some time to make sure the table is properly equipped with a working horn and a timing device. If there is a visible scoreboard, find out if the clock will be used and if it has an automatic horn for the end of the period. If not, be clear with the timer about the procedure for the end of the period.

Ideally, you will get to the game early enough to check the field thoroughly. However, no matter how rushed you are, you must check the goals before the opening face-off. It’s best to check them 20 minutes or so before the game so the home coach has time to fix them if necessary, then check them again right after the coin toss to make sure there are no balls left in the goal and no new holes. If you don’t check and there is a questionable goal and a hole in the net, one of the coaches is going to be furious.

The pre-game period is also a time for officials to communicate with each other. At higher levels, the pre-game may last an hour or more; at lower levels, it may consist of talking for a few minutes in the parking lot before taking the field. One of the first things to decide on a crew is where the crew members are going to officiate. Would the inexperienced official feel better working the far side of the field the entire game? How about in the closing minutes of a tight game? Do you want the experienced official on the bench side? The officials should also review mechanics, discuss any new rules interpretations, and determine if there are any special circumstances that they need to consider.



*Pre-Game  
Checklist*



*NCAA Timer  
Directions*



*NFHS Timer  
Directions*



*NCAA Scorer  
Directions*



*NFHS Scorer  
Directions*



*Coaches  
Certificatoin Cards*

## **GAME MANAGEMENT 2: FACE-OFFS**

The face-off is one of the keys to the game, most coaches tell their teams two of the keys to victory are winning face-offs and ground balls. Given this, face offs are one of the most challenging parts of the game to officiate and many players use many things to give them an advantage. Our job is to insure that they are legal, according the rule book.

Some key points to focus one to help manage a proper and legal face-off include:

- **In your pre-game, discuss if any of the officials have knowledge of the face-off players. Is there any awareness of “Cheating” (i.e. using their hands, clamping, etc...)? If there are discuss how one of the wing officials can assist in the face-off**
- **At the initial face-off of EVERY game, the face-off official should review with the face-off players the rules and mechanics of the face-off (crosses perpendicular to the ground, no hands on the plastic, the neutral zone is clear, all body parts to the left of the head, the mechanics will be down, set, whistle etc...)**
- **Use PREVENTIVE officiating for the first few face-offs, remind the players (or correct them) of incorrect face-off positioning, BUT after a few warnings, you need to call an illegal procedure if they continue to violate the rules. Also, REMEMBER OFFICIALS DO NOT COACH PLAYERS, talk to them as a group, don't pick out one of the players**
- **Remember on the face off (Youth and HS – NFHS) your cadence should be consistent. Down, slight pause to insure the players are in the correct face-off position, then set and a quick whistle. Also, remember your arms should be at your side, your whistle in your mouth and verbal commands only, no pumping of the arm.**
- **Face-off officials positioning is a personal decision, a recommendation is that on the first face-off position yourself if the neutral zone, you can get a better view of their overall position. After that, randomly change from the neutral zone to straddling the midfield line. This will allow for different views.**
- **If you are conducting a face-off with a player in the penalty area, remember to remind the table crew that the player CANNOT release until there is possession, whether the man down team brought a player up to the wing line or not. It is a good idea to know how much time is remaining on the penalty so the officials are aware of the situation also.**

***REMEMBER, A KEY TO GOOD GAME MANAGEMENT IS A GOOD, LEGAL FACE-OFF!***



## **GAME MANAGEMENT 3: MECHANICS**

Employing proper mechanics is another important part of game management. The standard lacrosse mechanics are designed to put you in position to make the correct call. While there may be times when you deviate from these mechanics, it should only be done for a specific reason and not just because you are lazy, out of shape, or just not paying attention.

Coaches and players can tell when you're out of position to make a call even though most of them couldn't tell you where you were supposed to be. When an official calls—or doesn't call—a crease violation from 25 yards away, or he calls an end line out-of-bounds on a shot while standing on the goal-line extended instead of after chasing the play, the official erodes the confidence that the players have in that official's calls, and that impacts game management.

On the other hand, if the official is in the right position to make the call and sells the call, it's much harder for the coaches and players to debate it. For example, on a close call of a goal or a non-goal due to a crease violation, an inexperienced official might give a soft whistle, jog in from 25 yards away, and give a half-hearted goal signal, which just encourages the defensive team's coach to argue that it wasn't a goal. However, when the experienced official blasts the whistle, sprints in from 5 yards away and emphatically signals "no goal; crease violation" there isn't going to be much argument, even if the play was so close the call could have gone either way.

Similarly, contested end line calls should have an official there, on the end line, making the call. If you do make a long-distance call, run in several yards while blowing the whistle so that when you announce the call you are nearer the infraction. Always hold your direction-of-play signal for a beat or two: it takes that long for the table and the coaches to find you and see the direction you're pointing.

## **GAME MANAGEMENT 4: DEAD-BALL OFFICIATING**

One complaint of many coaches and players is that some officials interrupt the flow of the game. Sometimes, that's coach-speak for "We wish they'd never call any fouls and just let them play," but other times they have a legitimate complaint, because the officials are supposed to keep the game moving as much as possible.

The most glaring example of this occurs during dead-ball situations. Dead-ball situations are not a rest time for officials: the officials need to work hard to make sure that play gets restarted quickly and appropriately. However, we tend to focus our training on what to do during live-ball play, so when play stops many officials aren't sure what to do, thus slowing down the game. This is not the only problem, since the coaches and players can sense when the officials aren't sure what to do, and that undermines their confidence in the officials. This is especially true in three-man mechanics, where the delays can be longer if the officials aren't working hard during the dead-ball situations. Good officials know how to anticipate the restart requirements during a dead ball or time-out so delays are minimal.

When there is a loose-ball technical foul, the officials need to stop play, report the foul quickly, and restart play. When reporting the foul, only the barest details need be communicated (i.e., say and signal "Loose, push! Blue ball!"; not "White, number 39, loose ball push in the back, blue ball!") unless there is something specific that needs to be explained because the call is unusual (and even then, keep it short). This is not a time for counting players or connecting with your partners; because the foul occurred during a loose ball, the proper number of players should already be on the field and your partners should be focused on the play. If the ball needs to be moved outside the attack area, do so quickly; if not, you should blow the whistle as soon as the ball is in the crosse of a player from the correct team and there are no other players within 5 yards. In fact, good, well-coached teams will be eager to start play and will pick up the ball and be ready to go as soon as you make the call; if you aren't ready when they are, they'll be asking, "Whistle? Whistle?" At the same time, remember there are no "running re-starts" (i.e., while the player with the ball doesn't necessarily need to be stationary when the whistle blows, he cannot be allowed to gain an unfair advantage by getting a running start before the whistle). Also, if the player with the ball is fairly close to the correct re-start location, let him start. Constantly stopping the game to get the player to stand exactly where they should is irritating to both teams.

This brings up another point: if you call a loose-ball push on player B1, and B1 wants to argue with you about it, you could warn him, ask him to address his concerns to his coach, or give him a conduct foul. However, sometimes a more effective way to end the discussion is to just start play while he's trying to argue with you. By doing so, you accomplish two things: you keep the flow of the game moving, and you punish B1 for arguing (since he's out of the play while trying to argue with you, essentially forcing his team to play man-down for a short time) without interrupting the flow of the game!

When there's a whistle for a non-time-serving foul (e.g., a ward, an illegal offensive screen, a loose ball push followed by the fouling team gaining possession), the rules require the offending team to place the ball on the ground or to give it to the nearest official. If a team tries to gain an advantage by rolling or throwing the ball away, thus making it harder for the other team to get a quick restart, this is illegal procedure and should be penalized. Of course, you need to use your judgment, because if the ball rolls a few yards there's really no advantage gained, and if they roll it a little bit farther you can let it slide with a warning (to the player, and repeated to the coach). But if they throw the ball far enough away that it slows down the game, it deserves a 30-second penalty. In this case, you interrupt the flow of the game once in order to ensure the game keeps moving later.

## **GAME MANAGEMENT 4: DEAD-BALL OFFICIATING (CONT.)**

For any time-serving penalty, the officials need to communicate the penalty to each other quickly and then communicate in detail to the scorer's table. Take your time communicating with the table area; this is your time to shine. Make eye contact and make sure they know what is happening. You're an official until you blow the whistle; at that time, you become a salesman. While the trail reports the penalty to the table, the other official or officials should get the ball to the right spot on the field. As soon as the trail finishes reporting the penalty and is sure the bench understands the foul, he should click his timer, after which the teams have 20 seconds to substitute if they desire. As soon as they are done subbing and are in position—or when the timer goes off, assuming the teams have the right number of players on the field—the officials should signal each other and play should resume. The players should not have to wait for the officials in this situation unless the officials need to correct a problem.

This is not to say that the officials cannot huddle to get things right if there is a complex penalty situation (e.g., B1 slashes A1, flag down; A1 passes to A2 who shoots and scores, but A1 slashes B1. Was the slash live-ball or dead ball? Is possession awarded or is there a face-off? What is the penalty situation?). In such a situation, it is more important to get things right than to keep the game moving. However, situations like these should not happen often, and if the officials must delay the game to huddle more than once or twice a game it can be a sign of poor officiating.

While one important aspect of dead-ball officiating is keeping the game moving, there are others. Often, when the officials stop play, they immediately look to each other to find out what the call is since they are concerned about getting the play restarted. However, if you turn to each other too quickly, you will eventually miss some residual action after the play such as a late hit or a slash after the whistle. These incidents have a huge impact on your game management, since often everyone sees them but you (and you often know that something happened but can't make the call because you didn't see it). Or, as often happens, you might see only the retaliation and not the act that precipitated it.

One key to dead-ball officiating is to make sure all residual activity from the play has stopped before you turn to take the call from your partner. Your partner should wait for you to make eye contact before starting to signal, so you shouldn't miss anything. Someone should always be watching the field and players at all times. A crew of officials can live with a missed offside call, but a missed late hit or off-ball high hit brings a game down quickly. Work just as hard at officiating in dead balls as in live balls. Watch the players cross during time-outs and the ends of periods from near the bench-side wing line before looking at your scorecard. Watch the teams cross again as they break from their huddles and go to their field positions.

Another key is that the trail official must focus on the shooter after the shot—and not the ball entering the goal—to make sure there are no late hits during the dead ball. If you miss these fouls, it leads to a high level of frustration among the coaches and players, which can lead to an out-of-control game.

## **GAME MANAGEMENT 5: COMMUNICATION**

### **General rules about communication**

Communication is a key and essential part of game management. By communicating with the coaches and players, you can often diffuse problem situations before the game gets out of control.

When you communicate, you need to be professional! Always refer to them as coach, do not use their first name, especially if you are friends off the field with them, you do not want to give any indication of a relationship as it could be detrimental to your managing the game.

A great time to establish a communication and rapport with the coach is during the pre-game certification. If do not know that coach, ask some basic questions, such how is the season going, do they have any rules questions, whatever you feel would be helpful in developing a basic relationship. If it is somebody new to coaching or new to lacrosse, you might communicate differently (i.e. you might ask periodically if they have any questions, there is nothing wrong with helping them along as long as you don't help or advise them on coaching).

### **If you establish a good rapport and relationship, a coach can become a great advocate for the officials.**

During the game, it is important to maintain your professional demeanor. For example, do NOT make any comments as to the play calling, the level of play or make any demeaning comments about their team or the other team. A comment like from a coach like "that was a terrible call", don't come back and say "coach that was a terrible play you ran." If a coach says you made a terrible call, either ignore it, or tell the coach what you saw (if the situation and time permits).

If a coach continues to berate you, you are always better to warn them to stop, but if you do, the next time you MUST, at the least conduct them. An example is, if you tell the coach you don't want to hear one more comment, if they do, you MUST, at a minimum conduct them.

Once the game starts, focus on what you need to communicate to manage the game and no more.

It is critical to avoid sarcasm; it is unprofessional and often misinterpreted by coaches. In fact, a large percentage of complaints about officials result from such misunderstandings.

This is not to say that you can't use humor. Humor is a great way to diffuse tense situations, although you need to be extremely careful. Try to observe the kind of humor used by experienced officials and learn from it, and remember don't be a comedian. A type of humor that seems to work best are self-deprecating humor (focused on yourself).

When you are faced with a verbal conflict, be sure to keep your voice level under control. If a coach screams at you and you scream back, you look bad, but if the coach is screaming and you're talking in a normal voice, the coach is the one that looks bad. Also, be aware of non-verbal communication: the way you say things and your body language while you're saying them often carry more weight than what you're saying.

The rules don't require you to address questions from the coaches (except at the end of halftime under NCAA rules or during a coach's challenge under NFHS rules), don't make the mistake of refusing to talk with them at all. If a coach has a respectful question about why you called something, answering it can keep the lines of communication open, maintain the coach's level of respect for you, and prevent frustration. Also, if you've made a difficult call—whether because it involves a poorly-known or –understood rule or because the play was close—letting the coach know why you made the call can achieve the same thing. The coach may not seem particularly interested in your explanation, but that's often because they're embarrassed about not knowing the rule better.

In the same vein, we all make mistakes, no coach has ever coached the perfect game nor has an official has ever officiated the perfect game (don't remind the coach he hasn't coached perfectly), if you make an error and realize it and if the coach questions you on the call, admit your mistake, apologize, tell the coach "I blew it, I missed that one, I am sorry..." quite often, that goes a long way with the coach and gets him to stop barking at you.

The best way to get a coach to stop barking is to restart the play quickly. Once live play is going, the coach is most likely focusing on the game, rather than you. For this reason, quick restarts are a key to successful game management.

Some people believe that on a controversial call it is better to leave the person who made the call on the far side of the field or even rotate him over to the far side. Actually, it is better to have him come over as soon as possible and "clear with air" with a quick explanation to the irate coach rather than to let the situation fester.

An often-overlooked means of communication is through body language. Coaches and players will zero in on an official who has the "deer in the headlights" look or who slouches when making calls as if unsure of himself. Conversely, they get irritated with the "gunslinger" who peers in to the play with arms wide and ready to sling flags. Stand, tall relaxed and have the attitude that you can handle whatever presents itself.

## **GAME MANAGEMENT 6: DEALING WITH CONDUCT ISSUES**

### **Coach and Player Conduct**

Even if you do everything right, there will always be games with poor conduct. Don't expect coaches and players to be rational or objective while they're involved in an emotional and physical game. There will often be times when they're certain you're wrong about a rule when you're right or when both coaches are sure you're favoring the other team. Furthermore, many coaches and players don't understand basic officiating principles such as mechanics and the principle of advantage/disadvantage. None of this, however, means you need to tolerate abusive behavior, either directed at you or among players, coaches, or spectators.

The first rule of dealing with coaches is that comments (e.g., "That's a slash!") can be ignored, while questions (e.g., "Why didn't you call a slash there?"; "Sir, could you please explain to me why we didn't get a free clear for that goalkeeper interference foul?") may or may not be responded to. Coaches are entitled to their opinions, and you can't expect them to coach with a muzzle. When they make comments about what they think should be called, it can generally be let go. If they politely ask questions and the game situation allows it, answer them whenever possible; this is an expected part of the official's job, and it also helps you to manage the game by building a relationship with the coach.

Dealing with players is essentially the same, except you'll ignore players with greater frequency than you'll ignore coaches.

However, there are lines you can't allow to be crossed. These include:

- **Profanity directed toward you or another game participant.**
- **Any player or coach questioning your integrity as an official.**
- **Direct criticism of you as an official (e.g., while you might ignore "That's an awful call," you can't ignore "You're an awful official!").**
- **Threats of any kind (e.g., "I'm going to get you in the parking lot after the game!"; "If you call one more penalty against my team you'll never officiate a game at this school again!").**
- **Any comments of a prejudicial or racist nature.**
- **A coach who is out of control. Adults who have lost control of themselves cannot be expected to control the kids playing.**

In cases of poor conduct, officials generally follow an escalating progression, starting with a verbal warning, followed by a conduct foul when the offending team has possession, then by a time-serving conduct foul, then a 1- to 3-minute unsportsmanlike conduct, and finally by a flagrant misconduct expulsion foul. Depending on the severity of the foul and what preceded it, steps in this progression may be repeated or skipped.

The important thing to remember is that, at some level, lacrosse is supposed to be fun, and that allowing this sort of behavior to continue makes it difficult for anyone to have fun, and it can ultimately degrade the contest into an unsafe situation because it can lead to excessively violent play and fighting. Officials who pride themselves on being able to handle a great deal of abuse aren't doing anyone any favors, particularly the next set of officials, who face a coach or players who think they can get away with any level of abuse. If you see this kind of behavior in your games, put a stop to it immediately.

### **Spectator behavior**

Dealing with spectators is another issue. If spectators have general comments about your officiating, ignore them. However, if they begin to use abusive language toward you or the players, or if they make threats of any kind, inform the site manager of the problem and ask that the problem fans be removed. Of course, the "site manager" at an NCAA Division I game is going to be very different than the one at a high school Varsity game played at a school stadium or a high school club game played at a public park; the rule of thumb is that you tell the home coach about the problem and ask that he take care of it; in the club game, he may have to do it himself, while at higher levels he may pass the assignment on to an athletic director or to school security. But if the problem is bad enough for you to notice it while officiating, it may be that some corrective action should be taken. In any case, never elevate the position of fans complaining about your officiating by addressing them directly.

## **GAME MANAGEMENT 6: DEALING WITH CONDUCT ISSUES (CONT.)**

It is important to keep spectators away from the field. Do not allow play to continue if there are fans within 6 yards of the sideline or on either end line. If necessary, be generous in your interpretation of “6 yards.” It’s a liability issue for you if someone who is too close to the field gets hurt, but it is also harder for the fans to abuse the players the farther away they are.

Under unusual circumstances, you may ask that the site manager eject certain fans (or even all of them). In most areas, it is rarely necessary to eject fans, but the need does arise. For example, suppose you have a high-school rivalry game with two physical teams, and a group of fans from one school is sitting at midfield and continually peppering the players from the other school with offensive remarks. If you try to ignore it, the physicality of the game may escalate as the fans get under the players’ skin. Instead, first have the site manager try to politely ask them to stop. If they continue to abuse the players, ask the site manager to remove the offending fans, and do not resume play until he or she complies.

### **Warning signs**

While there are times that a game will deteriorate so rapidly that you don’t have time to act, in many cases there are warning signs that alert you of the need to take corrective action. Spotting these signs comes with experience, but a few examples follow:

- **A sure danger sign is when players and coaches become more concerned with hitting than with trying to play good lacrosse. When hard body checks are drawing louder cheers than goals, when players knock down opponents and stand over them in a show of dominance rather than chasing after the loose ball they just created, these are signs that the game is taking a turn for the worse and that you need to take corrective action.**
- **In a two-man game, you’ve noticed A1 and B1 each take a couple hard shots at each other during the game, and A1 lays a big hit on B1, resulting in a turnover. B1 seems to take exception to the hit as the ball is being cleared by Team A. You’re the new trail, so in principle you’re supposed to follow the ball down the field, but you notice B1 lingering near A1. Even though you’re supposed to be watching the ball, everything in this situation screams out that you should watch and listen to A1 and B1 instead. You may hear B1 threaten A1 or see B1 commit a cheap shot; if you do, penalize it heavily, since B1 is counting on you being focused on the ball to take an opportunity to take an action that could result in a fight. He is probably also hoping that A1 will retaliate and that A1 will get caught. By focusing on these two players for a few extra moments, you are able to penalize the guilty party, remove A1’s incentive to take matters into his own hands, and discourage further away-from-the-ball antics because you’ve sent the message that you’re watching.**
- **Team A’s star midfielder A1 scores a goal and is drilled by B1 well after the goal. The trail official penalizes B1 for a dead-ball illegal body check. However, A1 is injured on the play and is carted off the field. Immediately after B1’s penalty expires and B1 re-enters the field, A2 subs onto the field carrying a crosse with a wooden shaft and chases after B1. Now, officially, there is nothing illegal about a wooden shaft, but the fact that you haven’t seen a wooden shaft all day—and then suddenly one of them is chasing after the player who injured the other team’s star player—is a pretty good indication that Team A may be seeking revenge and that the situation bears watching. There are various ways to proceed here; for example, one might be to talk to the Team A head coach and tell him what you saw. Explain that it is legal to use a wood shaft, but that you’re watching to make sure it doesn’t end up being used as a weapon, and you’d prefer it if you didn’t have to expel anyone today.**
- **One team starts sending in heavily-muscled substitutes who look like they are holding their crosses like battle-axes as they chase after the other team’s best players.**

When you see warning signs such as these, you need to take action, and game management shifts to game control.



## **GAME MANAGEMENT 6: DEALING WITH CONDUCT ISSUES (CONT.)**

### **Game control**

When you sense that the game is starting to deteriorate—or when it suddenly gets out of hand with no warning—it is time to clamp down on the game and make sure you limit the number of opportunities for problems.

Here are some techniques you can use to control the game when necessary:

- **You and your partners can set the threshold for calling fouls much lower. This will result in more whistles, more flags, and more people serving penalties but in fewer opportunities for actions that escalate into a fight.**
- **You can change the pace of the game, taking more time during dead balls to explain penalties and settling down the players before resuming play. Be generous in your interpretation of 5 yards on restarts, and make players stand completely motionless on the restart. This gives the players time to decompress. (This technique is especially effective in a running-time game.) Sometimes the faster, hotter, and more contentious the game the slower, cooler, and more soothing the officials have to act.**
- **If the benches are getting out of control, gather all of the coaches together and explain to them about the importance of honoring the game and setting a sportsmanlike example.**
- **If the situation warrants, explain that it's possible to play the rest of the game with a full penalty area, to expel players, or to suspend the game if the behavior doesn't improve. Explain that you're disappointed with their behavior and you're sure that they want to improve it so the rest of the game can be played. Tell them that your job is to keep the game safe, fair, and fun—in that order—and that you can take all of the fun out of the game if that's what it takes to keep the game safe.**

The key idea is that when the game is out of control, you have to use your whistle and flag to maintain order. That doesn't mean that you ignore the other aspects of game management, but if you need to flag or expel a few coaches or players to get your point across, do it.

### **Game termination**

When officiating youth games, the US Lacrosse Sportsmanship Card procedures should be used to deal with unacceptable behavior from players, coaches, and fans; the rules used for youth games have explicit procedures for game termination. The youth rules supplement to the NFHS rules support the philosophy that—since the primary responsibility of the officials is to protect the safety of the players and the culture of the game—then officials may terminate the game if the situation warrants it. Situations that might result in game termination include:

- **Threats made toward the officials**
- **A brawl or multiple fights before or during the game.**
- **Continued “dirty play” from one or both teams.**
- **Inappropriate fan behavior that is not corrected.**
- **Continued abusive language, taunting, baiting, or inflammatory comments from players, coaches, spectators, or fans.**

Although in extreme situations it might be reasonable to terminate the game immediately, in most cases you will call the head coaches together and explain to them that under the objectionable circumstances, you have no obligation to allow the game to continue. The “carding” of the coach (or coaches) indicates that the game is being continued under the Sportsmanship Card and the threat of game termination. Then, if necessary, follow through with the Sportsmanship Card provisions for terminating the game. Be sure to record the game situation (score, possession, penalties, time left and quarter) in case the game is to be resumed at a later date, call your assignor as soon as possible to explain the situation, and send the assignor a written report of the incident within 24 hours. Your partner should do the same.

## GAME MANAGEMENT 7: TYPES OF GAMES

There are certain types of games that require special attention. These include:

**The rout.** A game where one team is winning by a large margin, you face the serious risk that the losing team will start taking cheap shots out of frustration. You need to be extremely vigilant despite the fact that the game has probably already been decided. The bright side is that routs are easier to manage than close games because it is extremely unlikely that any call you make will have an impact on the outcome of the game. If there's any kind of scuffle, even a minor one, send both players involved to the penalty area for one to three minutes (non-releasable, since they'll be starting their penalties at the same time); this will create more space on the field and make it less likely that you will have problems. If you explain to the leading coach that you're trying to keep things settled down and to protect his or her players by getting some players off the field, he'll understand.

One consideration when sending two players off for a minor scuffle or altercation: under NFHS rules, a second non-releasable unsportsmanlike conduct foul results in an expulsion (and, in most states, a suspension for a subsequent game or games). Thus, it often makes more sense to send the players off for unnecessary roughness instead; the penalty is the same (since they're getting sent off at the same time, the penalties will be non-releasable) and you avoid having to expel any players. Of course, if the players' actions warrant, give the unsportsmanlike conduct penalty, but this option gives you a lesser foul when it's appropriate.

The most important thing to remember in a rout is that you can't become sloppy just because the result of the game has essentially been decided. Do whatever it takes to keep your head in the game, because ignoring game management in a rout can put you in the middle of the brawl if the frustration level of the losing team is allowed to grow unchecked.

In a rout in a lower-level game, you might inquire discreetly to the coach getting beaten if he wants to keep the full time on the clock or shorten the periods, or have the clock operator be judicious in allowing the clock to run a few seconds after the whistle blows. Again, these tips work best in youth games and almost never should be broached at a college game. In the latter, let the coaches initiate that conversation with you.

**The elimination game.** In playoff games, teams tend to be more evenly matched, and the importance of the game tends to make players play more in control since no one wants to be the one who took a dumb foul in a close game and cost his or her team the chance to win. Still, emotions run high in these games, and you must carefully monitor the situation, especially when the game is not close.

Tournament games are similar, except that there are often many games played in one day, which leads to physical, mental, and emotional fatigue in the players, coaches, fans, and even spectators. In particular, tired players are more likely to play sloppy lacrosse and to play defense with their sticks instead of their feet and heads, leading to more fouls.

Always protect the team "going through to the next round," as a losing team might want to incite a scuffle to prevent a winning opposing player from participating in the next tournament contest. Is the winning-team player actually actively involved in an incident, or was he merely raising his arm to protect himself?

Also, you should always be aware of the weather conditions, but this is especially true for tournaments held in hot, humid conditions. The NFHS Rules and US Lacrosse Youth Rules specifically allow for the officials to call extra time-outs to help players deal with the heat, and this is never more important than when the teams play multiple games in these conditions.

**The rivalry game.** Rivalry games come in a variety of styles. They can be games between schools that:

- **Have a traditional rivalry in all sports.**
- **Have a rivalry in lacrosse only.**
- **Have a history of bad blood arising from on- or off-field incidents.**
- **Just don't like each other.**



## **GAME MANAGEMENT 7: TYPES OF GAMES (CONT.)**

There is some debate about how the assignor should handle rivalry games. One school of thought is that the officials should be told of the rivalry so they are ready to take control of the game from the start. The other view is that you're better off not telling the officials since doing so creates preconceptions that might influence how they call the game. There is no clear "correct approach."

If you are assigned to a rivalry game, you need to make a decision about whether to say anything to the coaches before the game. Some officials will warn the coaches that the game will be called tightly from the start, while others simply speak with the coaches as if it were any other game. Again, there is no "correct approach," but warning the coaches before the game may create the impression that you have pre-judged the teams, so be careful. You need to officiate the game that presents itself.

One significant difference in a rivalry game is that there may be an emotional crowd, which can, in turn, amplify the emotions of the players. As an official, you don't want to pay too much attention to the spectators, but be aware of how the players are reacting to them. With an emotional game, you tend to see more aggressive players and more obvious fouls.

In a rivalry game, you'll probably start out calling things a little more tightly than you would for two teams that rarely play each other because you know there is a significant risk of cheap shots escalating. That doesn't mean you have to call every foul, just that you send a message that it's not going to be a free-for-all where no fouls are called at all. When players believe that the officials are not going to penalize fouls, they will often decide to take matters into their own hands, and this is especially true in a rivalry game. If the teams get the message and behave themselves, you can ease off a bit as the game goes on.

The inexperienced team. In youth lacrosse, or at higher levels of play where most of the players are playing lacrosse for the first time, you may be faced with one or two teams with little idea what they are doing. Perhaps the coaches don't know the game either. When this happens, you shouldn't worry too much about being accused of coaching; instead, do what it takes to help the teams get through the game. You may take extra time to correct face-off positioning or to explain to people that you actually did see the loose-ball push and had a play-on for it but since the fouled team gained possession, there was no need to stop play.

In a game like this, the players are likely to commit fouls due to lack of control and ignorance rather than intent and testosterone, so when you flag someone try to make sure that he understands what he did wrong and that it's all part of learning the game. If you see something that hints at a team-wide misconception (e.g., the players continually go into the opponent's crease), politely explain the rule to the coach so he can relay it to the players; this reduces everyone's frustration level.

If only one team is inexperienced, you may find that the game is also a rout. In that case, the usual warnings about routs apply. Be especially alert to an athletic but unskilled new team getting embarrassed and trying to take out their frustrations physically.

## **GAME MANAGEMENT 8: THE PRINCIPLE OF ADVANTAGE/DISADVANTAGE**

You should not automatically penalize everything you see that is technically, according to the rules, a foul. Doing so makes for a tedious game and will earn the ire of the coaches, players, and fans. The difficult part is determining which fouls to call and which to ignore. The guiding principle for these situations is called “The Principle of Advantage/Disadvantage.” The basic idea is that you should call:

- **Fouls that present a safety issue (which includes most personal fouls).**
- **Fouls that you must call to maintain proper behavior (conduct fouls and unsportsmanlike conduct fouls).**
- **Fouls that are obvious to everyone (e.g., line violations, such as crease violations and offside).**
- **Technical fouls that disadvantage the fouled team or create an unfair advantage for the fouling team.**

The last item is the most difficult to explain, and is most easily seen by example.

Suppose player A1 is running down the field clearing the ball and B1 pushes him from behind, making him stumble briefly. If A1 doesn't fall or lose possession of the ball, there's probably no need to call a foul. However, if B1 commits exactly the same push in a different situation, a flag for the push may be appropriate. For example, the push might cause A1 to:

- **Go out of bounds.**
- **Go offside.**
- **Step into the crease.**
- **Move past the goal, making him miss a scoring opportunity.**
- **Lose possession.**

In each of these cases, A1 has been disadvantaged by the foul and so the flag must be thrown.

So, whenever judging technical fouls, try to determine whether an advantage has been gained before calling the foul. This is not easy, and may take you a few years to get comfortable with these kinds of decisions; talking to experienced officials about why they did or didn't call a foul can help you learn this important principle.

## GAME MANAGEMENT 9: THE PLAY-ON

Proper use of the play-on technique is important for proper game control. Many newer officials have a hard time remembering when to use the play-on, and so some of the nuances of its use for game control are lost on them. It is important to understand the reason the play-on exists in order to apply it in a way that helps your game management.

The play-on was devised primarily for the area between the defensive restraining line and the midfield line.

It is here where fewer players will generally be involved in the play. This can occur before possession is declared on the face-off as well as an errant pass coming out of the attack goal area.

The main idea behind the play-on is that it allows play to continue so that a team that is on the receiving end of a loose-ball technical foul can continue play without being disadvantaged. It has the added feature of improving the flow of the game by reducing the number of whistles.

For example, suppose B1 pushes A1 from behind during a loose ball, and then A1 immediately scoops up the ball and has a clear path to the goal. Blowing the whistle for the loose-ball push actually disadvantages Team A; if you stopped play, you'd just be awarding them possession, which they already have, and that clear path to the goal is not going to be there when the play restarts. Furthermore, even if there hadn't been a clear path to the goal, allowing play to continue means there's one fewer whistle blown and the game keeps moving. This is what the play-on was designed for.

Although calling a play-on around the crease area is following protocol, this would not be wise since other fouls can occur. If a defensive player commits a personal foul, the defensive team will be playing with a man down. If an offensive player commits a personal foul, then this will lead to a simultaneous situation with the defensive team being awarded the ball. This would now be a big disadvantage to the offensive team (who had been fouled originally). Whenever there is a situation such as this, immediately blow the whistle, indicate the loose ball foul, and restart the game 20 yards laterally.

For example: In a loose-ball scrum with 8 players, B1 pushes A1 from behind. If you allow play to continue and A1 scoops the ball, he's likely to get the ball checked right out of his stick or be fouled again, so in this case it makes sense to kill the play fairly quickly. Here, you do not disadvantage Team A with a quick whistle.

How long you wait before blowing the whistle on a play-on is a key aspect of game management. Some guidelines:

- **The lower the level of play, the shorter the play-on should be. A newer official on a youth game might want to not use them at all. At lower levels of play, players are much more likely to get hurt during loose-ball scrums, so it makes sense to end those plays as quickly as possible. In fact, during loose-ball scrums at low levels—and often in higher-level games where play is starting to get out of control—you should be looking for any technical foul you could possibly call to get the ball off the ground. While people may accuse you of making a “picky” call, letting the loose-ball scrum continue too long can be hazardous.**
- **If the ball pops out of the scrimmage area and it seems likely that a player from the fouled team will be able to track down the ball and scoop it uncontested, you can allow the play-on to continue for quite a bit longer. However, if the player seems to be trying to delay scooping the ball to take time off the clock, blow the whistle and award possession.**
- **A North-South play-on is better than an East-West play-on, and a play-on in the attack half of the field is better than a play-on in the defensive half of the field.**
  - o What would a fouled team rather have: a nice clean restart with all players five yards away or uninterrupted possession of the ball at that moment?
  - o What advantage have you given a player who scoops up a loose ball during a play-on right on the sideline surrounded by three defensemen? You must decide.
  - o If you can answer those two questions, then you understand the concept of the play-on.

## **GAME MANAGEMENT 10: MISTAKES BY OFFICIALS**

All officials will occasionally blow a call, with, of course, the better officials making fewer mistakes. This can be because of a rule misunderstanding or misapplication, because the official was out of position to make the correct call, or because the official just didn't see what actually happened. Whatever the reason, how you handle making a mistake can have a huge impact on your management of the game.

The best way for the crew to handle a mistake is to huddle and correct the mistake before it has an impact on the game. Often, one official will realize that a call is incorrect but won't want to "show up" a fellow official and will keep his or her mouth shut, but most coaches and players will have much more respect for the crew if they meet and get the call right. In other situations, where you blow a call and realize it (or you call a play that was close enough that you realize you may or may not have gotten the call right), honesty is often the best policy. If the coach is mad because he says you blew the call, and you say, "You're right coach, I'm sorry, it won't happen again," it's very difficult for them to keep up a tirade. Just don't put yourself in a position where you need to do this too often!

It's also important to know what to say to the coach by your side when the far-side official makes a marginal call. Never "throw your partner under the bus." Practice responses such as:

- **"Coach, he was right there."**
- **"Coach, it's hard to tell from 50 yards away where we are."**
- **"He had a good angle there, Coach; he must have seen something we didn't."**

If your partner makes a call that the coach doesn't understand and you don't know what the call was either, tell the coach you'll check with your partner and ask what about the call when there's a break in the action, then remember to follow up with your partner and the coach.

If a mistake is made – don't make it worse with quick restarts and confusion. Communication to crew/players/table and coaches is critical.

If needed give teams the chance to get the right players on the field or in position. Examples might be:

- **Pointing in wrong direction**
- **Inadvertent whistle/flag**
- **Overruled call**

Tips to prevent mistakes

- **Know the rules**
- **Do not "fish in someone else's pond" unless you are 110% sure**
- **If you keep seeing you partners mistakes – Who is watching your area?**
- **Never pass on a Personal Foul**
- **Did you partner not see a call a call or did he "pass" on it? If he passed what is the reason?**



US LACROSSE  
OFFICIALS  
EDUCATION  
PROGRAM

**APPENDICES**

## **APPENDIX I: AVAILABLE TRAINING TOOLS**

### **US Lacrosse Men's Officials Educational Content**

[www.uslacrosse.org/menofficialsresources](http://www.uslacrosse.org/menofficialsresources)

#### **Training Materials**

- Officials Training Manual
- 3rd Team on Field DVD
- Rules Interpretation Video
- 'You Make the Call' video clips
- Online Testing Administration and Tracking

#### **Classroom Curriculum (PowerPoint files)**

- |   |  |
|---|--|
| <ul style="list-style-type: none"> <li>• Two-Man Mechanics</li> <li>• Three-Man Mechanics</li> <li>• Being a Mentor</li> <li>• Boys' Youth Rules Training</li> <li>• Clock Management</li> <li>• Game Management</li> <li>• Conducting a Proper Pre-Game</li> <li>• Conducting a Proper Post-Game</li> <li>• How to be a Crew Chief</li> <li>• Keys to Consistency</li> </ul> | <ul style="list-style-type: none"> <li>• Penalty Enforcement</li> <li>• Personal Fouls</li> <li>• Rules 1, 2 and 3</li> <li>• Rule 4 Play of the Game</li> <li>• Safety, Multiple Minutes, Ejection Fouls</li> <li>• Simultaneous Dead Ball and Multiple Foul</li> <li>• Teaching Lacrosse Clinics</li> <li>• Technical Fouls</li> <li>• Working With New Officials</li> </ul> |
|---|--|

#### **Evaluation Forms**

- Junior Officials
- Level 1 Officials
- Level 2 Officials
- Level 3 Officials

#### **Officials Resources**

- NCAA Directions for **Timer** | **Scorer**
- NFHS Directions for **Timer** | **Scorer**
- **Field Diagram (Blank)**
- **Field Diagram (Dimensions)**
- **Game Bag Tips**
- **Scorecard**
- **Coaches Certification Card**
- **Animated Officials Signals**
- **Junior Officials Supplement (PDF)**
- **Uniform Checklist**
- **Pregame Card**
- **Fouls Decision Tree**



*Arbitersports US Lacrosse  
Officials Central Hub*



*Men's Officials  
Resources*

## **APPENDIX II: HOW OFFICIALS HONOR THE GAME**

By getting coaches, parents, and administrators on the same page about Honoring the Game before the season starts, we hope to reduce the number of negative incidents that occur at youth games. However, even with the right training and expectations in place, negative incidents still happen. This is when it is particularly important for game officials to have a plan. Here are a few tips to get you started —please refer to the “Post Game” section for more information.

The PCA recommends that officials always introduce themselves to the coaches before the start of the game. Officials at youth games can remind coaches that they expect them to take responsibility for the conduct of their fans, and if there is trouble during the game with the fans, the officials will come to the coaches to ask for their help in taking care of this problem. Officials and coaches should view themselves as working together to create and maintain a positive environment for the players.

Unfortunately, on some occasions officials have to deal with abusive behavior from coaches. In these cases, where coaches are no longer Honoring the Game, officials bear the ultimate responsibility to ensure players are taking part in a safe and positive environment. Although it is neither fun nor easy, officials need to address abusive coaches in a calm and respectful manner to remind them that their conduct is inappropriate. If the situation persists, coaches should be warned that the game is in danger of being terminated.

By spreading the Honor-the-Game message to all involved in lacrosse, we hope to improve the game environment for officials, hence addressing the constant lack of officials. Officials should view themselves as an important adult group working to support a culture that Honors the Game, and they should feel joined in this effort by coaches, parents, and administrators. Positive Coaching Alliance and US Lacrosse are here to help you.

US Lacrosse asks you to consider your role in Honoring the Game, showing respect for all the people working together to make lacrosse the great game that it is. Take this simple test—and be sure you can check off every one before you head out to officiate:

I understand and will reinforce that the safety of the participants in the game is more important than the final score.

I understand that lacrosse officials do not make the rules, they only apply them.

I understand that children learn from adults, and my behavior reflects what I want children to learn.

I value the contribution of coaches in developing players’ talents, even though I may not always agree with their strategies.

I understand that I must consider the level of play when officiating and respond accordingly.

I understand that the biggest reason for players (and officials!) quitting the game is verbal abuse.

I understand that players, coaches and officials are learning the game, and mistakes will be made in the learning process.

I understand that officials are responsible for ensuring that the game is played in a safe and fair manner for all participants.

Thank you for your help in the efforts to make lacrosse a positive experience for everyone!

## **APPENDIX III: US LACROSSE CODE OF CONDUCT**

### **The Code of Conduct**

Players, coaches, officials, parents, spectators and fans are to conduct themselves in a manner that “Honors the Game” and demonstrates respect to other players, coaches, officials, parents, spectators, and fans. In becoming a member of the lacrosse community an individual assumes certain obligations and responsibilities to the game of lacrosse and its participants. The essential elements in this “Code of Conduct” are honesty and integrity. Those who conduct themselves in a manner that reflects these elements will bring credit to the sport of lacrosse, themselves, their team and their organization. It is only through such conduct that our sport can continue to earn and maintain a positive image and make its full contribution to amateur sports in the United States and around the world. US Lacrosse supports the following behaviors for those participating or involved in any way with US Lacrosse in general. The following essential elements of the “Code of Conduct” must be adhered to:

- **Sportsmanship and teaching the concepts of fair play are essential to the game and must be taught at all levels and developed both at home and on the field during practices and games.**
- **The value of good sportsmanship, the concepts of fair play, and the skills of the game should always be placed above winning.**
- **The safety and welfare of the players are of primary importance.**
- **Coaches must always be aware of the tremendous influence they have on their players. They are to strive to be positive role models in dealing with young people, as well as adults.**
- **Coaches should always demonstrate positive behaviors and reinforcement toward players, parents, officials and spectators alike. Players should be specifically encouraged and positively reinforced by coaches to demonstrate respect for teammates, opponents, officials, and spectators.**
- **Players should always demonstrate positive behaviors and respect toward teammates, opponents, coaches, officials, parents, spectators, and fans alike.**
- **Coaches, players, parents, spectators, and fans are expected to demonstrate the utmost respect for officials and reinforce that respect in his or her players. Coaches are also expected to educate their players as to the important role of the lacrosse official and to reinforce the ideal of respect for the official by his or her players.**
- **Grievances or misunderstandings between coaches, officials or any other parties involved with the sport should be communicated through the proper channels and procedures, never on or about the field of play in view of spectators or participants.**
- **Officials are professionals and are therefore expected to conduct themselves as such and in a manner that demonstrates total impartiality, courtesy and fairness to all parties.**
- **Spectators involved with the game must never permit anyone to openly or maliciously criticize, badger, harass, or threaten an official, coach, player or opponent.**
- **Coaches must be able to demonstrate a solid knowledge of the rules of lacrosse, and should adhere to the rules in both the letter and the spirit of the game. Coaches should encourage and help to educate the players and spectators surrounding his or her program to develop a basic knowledge of the rules. Attempts to manipulate rules in an effort to take unfair advantage of an opponent, or to teach deliberate unsportsmanlike conduct, is considered unacceptable conduct.**
- **Eligibility requirements, at all levels of the game, must be followed. Rules and requirements such as age, previous level of participation, team transfers, etc, have been established to encourage and maximize participation, fair play and to promote safety.**



## **APPENDIX IV: US LACROSSE BENEFITS FOR OFFICIALS**

US Lacrosse provides a large number of benefits to its member officials, including:

- **Men's game Lacrosse Referee Development (LAREDO) on-field officials development programs.**
- **Liability insurance.**
- **Discounts on lacrosse officials uniform starter packages.**
- **Game fee insurance (for when you are hurt while officiating and miss officiating scheduled games; contact Bollinger insurance for full details).**
- **Secondary medical insurance.**
- **A free copy of the NFHS or NCAA rule book each year.**
- **Online rules testing.**
- **A subscription to *Lacrosse Magazine*.**
- **Discounts through the US Lacrosse store.**
- **Free admission to the US Lacrosse Museum in Baltimore.**
- **Access to US Lacrosse training and materials, which is continually being improved and expanded.**
- **Access to the US Lacrosse Convention, held in January of each year, which provides a full program of officiating clinics.**
- **The men's game e-mail newsletter (for collegiate officials).**
- **The men's game Resources Page, which houses a number of useful documents for men's officials.**
- **Membership in local US Lacrosse chapter.**
- **Annual men's game awards.**
- **Customer service support.**
- **Nationwide support for the development of the sport of lacrosse.**

In order to continue to receive your benefits, you must keep US Lacrosse updated with your current e-mail and home addresses. If you have a change to report, or if you think you are not receiving the correct correspondence from US Lacrosse, contact [membership@uslacrosse.org](mailto:membership@uslacrosse.org).

You can join US Lacrosse online by going to [www.uslacrosse.org](http://www.uslacrosse.org)



*US Lacrosse  
Membership Info*

## APPENDIX V: FOULS DECISION TREE



### Personal Foul Flow Chart

- Time is always served for all personal fouls.
- Flag should always be thrown for personal fouls (Live or Dead Ball).
- Personal Fouls are either 1, 2 or 3 minutes of penalty time

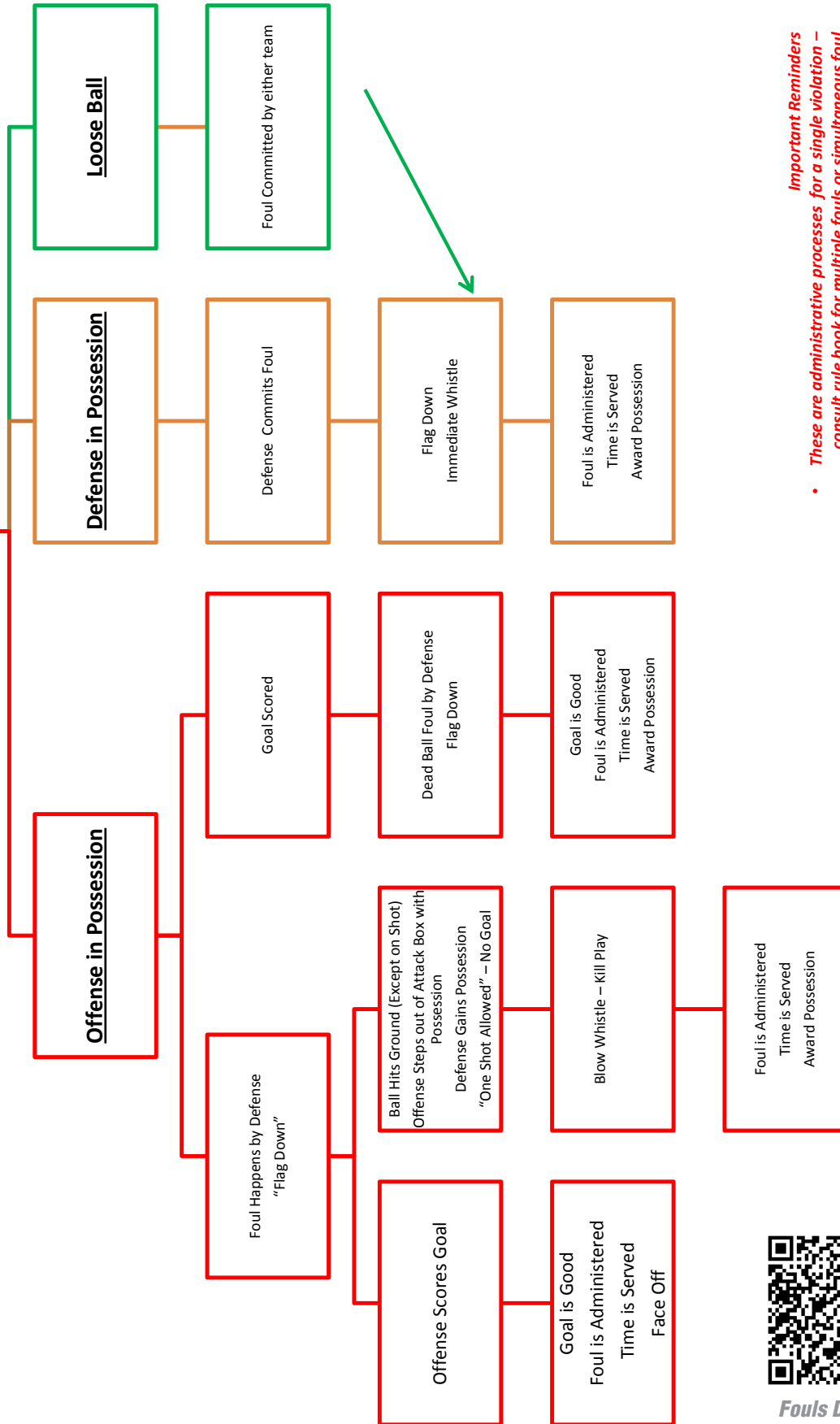

*Important Reminders*  
 • These are administrative processes for a single violation – consult rule book for multiple fouls or simultaneous foul situations



Fouls Decision Tree



## APPENDIX V: FOULS DECISION TREE

- 4 things can happen as a result of a technical foul:
- Nothing (Offended gains possession & maintains Advantage)
  - Award Possession based on offended team not obtaining ball or advantage
  - Penalty Time
  - Turnover or Take the Ball Away

### Technical Foul Flow Chart

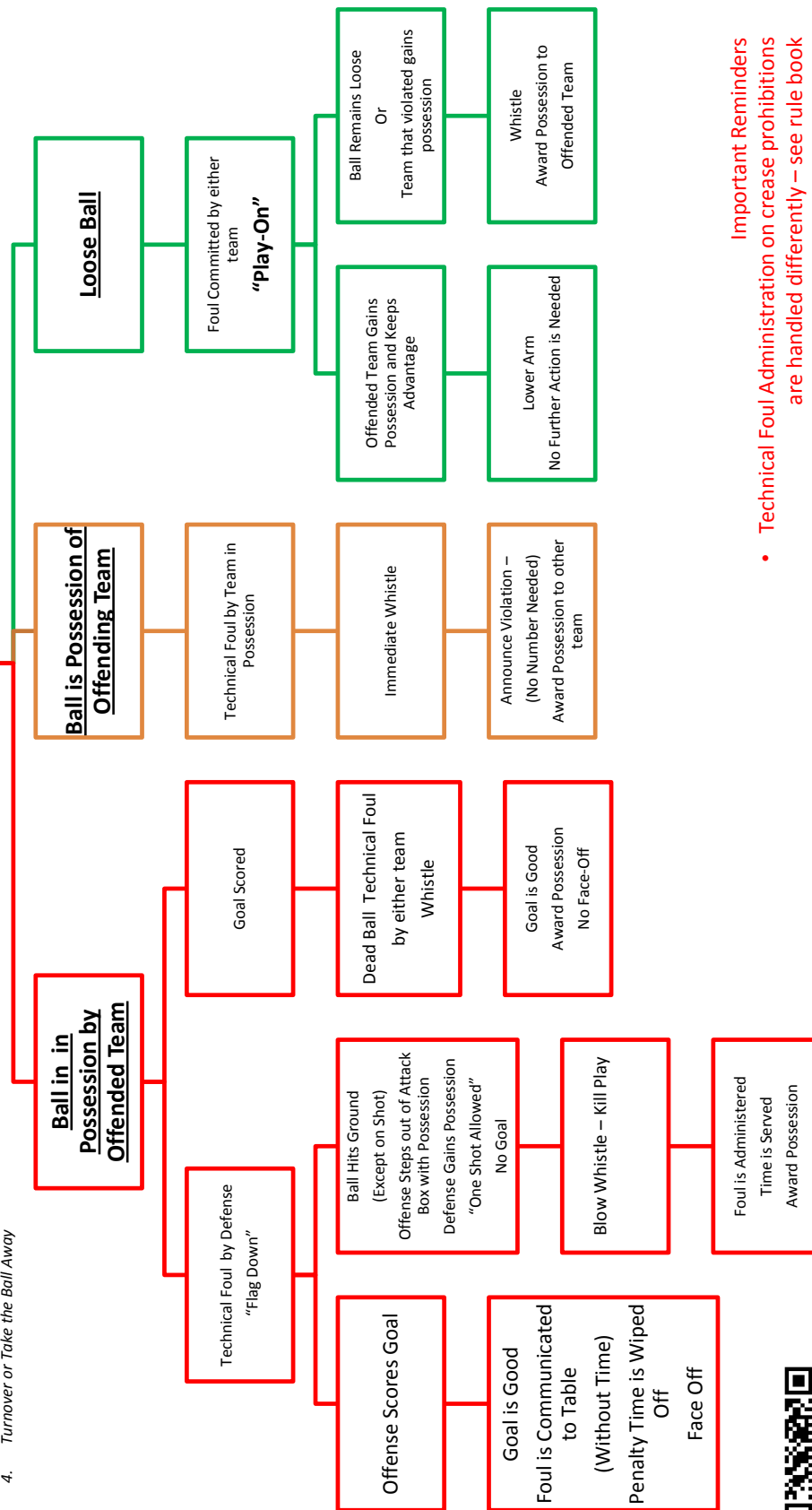

- Important Reminders**
- Technical Foul Administration on crease prohibitions are handled differently – see rule book
  - These are administrative processes for a single violation – consult rule book for multiple fouls or simultaneous foul situations



Fouls Decision Tree

# APPENDIX VI: USL ONE PAGE PREGAME FOR OFFICIALS



## LACROSSE PRE-GAME (2 or 3 Man)

### I. CREW PREPARATION & GAME LOGISTICS

- A. POSITION ASSIGNMENTS (Starting Positions, Rotation)
- B. OFFICIALS ASSIGNMENTS – (Captains, Stick/Equipment Checks, Ball Boys)
- C. COACH'S MEETING
  - CERTIFICATION - Captains, In-Home, Crew Card
  - REFEREE INSTRUCTIONS (Coaching area during timeouts, Bench decorum)
  - NEW RULES & INTERPRETATIONS
- D. PRE-GAME INSTRUCTIONS – ALL OFFICIALS CHECK FIELD, WATCH PLAYERS
  - UNIFORMS
  - GOALS
- E. COIN TOSS (Determine Alternate Possession, Review Player Decorum & Mouthpieces)
- F. TIMEOUTS (Officials Positioning, Timer)
- G. HALFTIME (Clear Field, Start Clock)
- H. OVERTIME – One Timeout per OT Period, Coin Toss for Direction Only (AP stays same)
- I. POSTGAME (Approve Score, Watch first cross by teams, Walk Off As Crew)

### II. POINTS OF EMPHISIS

- A. FACE-OFF
  - Unsportsmanlike Conduct
  - One Hand on stick
- B. HIGH HITS
- C. PACE of GAME
  - A. Stalling vs. Zone
- D. UNCONTROLLED CHECKS

### III. MECHANICS

- A. ALWAYS COUNT PLAYERS & CHECK THE CLOCK
- B. HAND SIGNALS
  - BOUNDARIES (Two Arms Up if sideline out of bounds)
  - RESTARTS (Arm Up, Wind Clock)
  - FACEOFF (No more point – no set call, Pump clock)
  - IN GOAL AREA (No arm up any longer, HOLD POINT make sure partner stops count)
  - FOULS (Move to Open Area, Relay to Trail)
  - ALTERNATE POSSESSION (Signal Face-off & Point Direction)
  - WHISTLES (Mechanic if there is a multiple whistle, “Staccato” to take away a call)
- B. SUBSTITUTIONS (Box official has timer & player counts, player on field has right of way)
- C. BOX COVERAGE (Lead's responsibility if ball is Behind Defensive Clearing Line, otherwise Trail Has Box)
- D. RESTARTS (Relay Ready Signal Through Center, Wait Until Goalie is Ready)
  - PLAYER ON OR BEHIND PROPER POSITION (Player and Goalie Are Ready – Restart Immediately)
  - PLAYER NOT IN PROPER POSITION (Reposition Only if Improper Position Gains Advantage)
- E. FACEOFFS (Trail pumps & has timer after goal, Trail restarts after violation)
  - STAY AND OFFICIATE AS NEEDED
  - STAND WHERE NEEDED – Wings officials help with “HOT” side hands
  - CREW CONSISTENCY - Player instructions, Quick whistle
  - MAN-DOWN FACEOFF – Point out on-side man as reminder
- J. COUNTS
  - Goalie
  - 30 Seconds – goal coverage, trail still counts
  - GET IT IN KEEP IT IN - 10



Pre-Game Checklist

- C. COUNTS
  - LOOSE BALLS BETWEEN THE RESTRAINING LINES
  - MAN DOWN CLEAR/PRESSURE RIDE
- D. STALLING – (NO TRAPS)
- E. FINAL TWO MINUTES (Shot or Deflection Out Of Box, Use Of Play-On Technique)
- F. FIGHTING (Trail Freezes Both Benches, Lead & Center Control Fight.)
- G. CREASE COVERAGE (2 Man vs 3Man)
- H. COUNTS
- I. RESTARTS – NCAA vs NFHS
  - Offside
  - FACEOFF VIOLATIONS
  - “QUICK RESTART RULES”

### IV. SPECIAL SITUATIONS – NCAA vs NFHS Rules

- A. FOULS (Simultaneous vs. Multiple, Live Ball or Dead Ball, Releasable)
  - FLAG DOWN
- B. PLAY-ON (Do Not Disadvantage Offended Team, Stop Play Quickly, No Subsequent Fouls)
  - Midfield, Wing lines, Sidelines & End lines
  - GOALIE INTERFERENCE - VERBAL CALL
- C. POSITION – UNSETTLED SITUATIONS
  - LOOSE BALLS BETWEEN THE RESTRAINING LINES
  - MAN DOWN CLEAR/PRESSURE RIDE
- D. STALLING – (NO TRAPS)
- E. FINAL TWO MINUTES (Shot or Deflection Out Of Box, Use Of Play-On Technique)
- F. FIGHTING (Trail Freezes Both Benches, Lead & Center Control Fight.)
- G. CREASE COVERAGE (2 Man vs 3Man)
- H. COUNTS
- I. RESTARTS – NCAA vs NFHS
  - Offside
  - FACEOFF VIOLATIONS
  - “QUICK RESTART RULES”

### V. COVERAGE

- A. LEAD (2 or 3 Man)
  - TRANSITION (Must Beat Bail Downfield)
  - POSITION (Goal Line Extended)
  - COVERAGE (Bench Side Offensive Area to Restraining Line)
  - BOUNDARIES
  - RESTARTS
  - COUNTS
  - GOALS
  - SUBSTITUTION AREA COVERAGE
- B. CENTER – (3 Man)
  - TRANSITION (Responsible For Late Hits, Cover Goal Line On Face off)
  - POSITION (5-10 Yards Above Crease, Cover Goal Line For Lead)
  - COVERAGE (Far Side, Transition Off-Sides)
  - BOUNDARIES (Far Sideline)
  - RESTARTS (Far Sideline Above Defensive Clearing Line)
  - COUNTS (Far Side Alley, First 10 Across until Trail is out of Box areas)
  - GOALS (Find Shooter, Keep Players In Vision, Responsible for USC)
- C. TRAIL – (2 or 3 Man)
  - TRANSITION (Primary is far goal line, Late Hits on Shooters)
  - POSITION (5 Yards Above Box)
  - COVERAGE (Off-Sides & Substitutions, Late hits)
  - BOUNDARIES
  - RESTARTS
  - COUNTS
  - GOALS (Responsible for Late Hits)
  - SUBSTITUTION AREA COVERAGE

**Officials Checklist**

Crew Cards • Timer • Hat • Flags (2) • Coin  
Whistles (2) • Scorecard • Pencil • Tape Measure

## APPENDIX VII: US LACROSSE JUNIOR OFFICIALS EVALUATION FORM

Official: \_\_\_\_\_ Evaluator: \_\_\_\_\_ Date of Evaluation: \_\_\_\_\_

Game Level: ----- Difficulty of Game:  Easy  Competitive  Difficult  Very Difficult

Home Team: \_\_\_\_\_ Visiting Team: \_\_\_\_\_

### Part 1 – Game Management

Category	Meets Expectations	Needs Some Improvement	Not Observed	Comments
Does the official display proper time management throughout the course of the game				
Does the official have the ability to keep the game under control				

### Part 2 – Rules Knowledge and Application

Does the official display knowledge of the youth rules				
Does the official display proper application of youth rules				
Does the official demonstrate sound judgment and consistency throughout the game				

### Part 3 - Mechanics

Does the official demonstrate proper positioning and mechanics				
Does the official demonstrate proper hand signals and verbal communication when making calls				
Does the official demonstrate hustle and the ability to get into proper positioning				

### Part 4 – Comportment

Does the official show display a professional attitude and appearance while on the field				
Does the official show the ability to work as a team on the field with their partner				

### General Comments

\_\_\_\_\_



*Junior Officials  
Evaluation Form*

## APPENDIX VII: US LACROSSE JUNIOR OFFICIALS EVALUATION FORM

This Junior Officials Evaluation is to be completed by a certified Youth Officials Trainer with US Lacrosse in. This is the evaluation a junior official will need to have completed and passed in order to become a Certified Junior Official with US Lacrosse. In the above evaluation form please keep in mind the two main categories in addition to the “Not Observed” category when observing the official on the field. Also the MGTC feels it is very important to provide written feedback to each official being evaluated. Please make sure you provide any additional feedback for the official in order to provide him with as much information as possible, regarding what he should work on during the season.

<b>Does the official possess proper foul recognition for the level of play?</b>	<input type="checkbox"/> YES <input type="checkbox"/> NO <input type="checkbox"/> Not Observed
<b>Can the official properly conduct a face-off?</b>	<input type="checkbox"/> YES <input type="checkbox"/> NO <input type="checkbox"/> Not Observed
<b>Does the official understand the four primary spots to be on the field in certain situations?</b> <ul style="list-style-type: none"> <li>• <b>Lead</b> <ul style="list-style-type: none"> <li>○ Goal Line Extended</li> <li>○ End line and Sideline</li> </ul> </li> <li>• <b>Trail</b> <ul style="list-style-type: none"> <li>○ Change of possession</li> <li>○ Settled position (5 in 5 out)</li> </ul> </li> </ul>	<input type="checkbox"/> YES <input type="checkbox"/> NO <input type="checkbox"/> Not Observed
<b>Does the official display a proper strength and use of their whistle?</b>	<input type="checkbox"/> YES <input type="checkbox"/> NO <input type="checkbox"/> Not Observed
<b>Does the official display the proper mechanics after a goal is scored?</b>	<input type="checkbox"/> YES <input type="checkbox"/> NO <input type="checkbox"/> Not Observed
<b>Does the official display proper timing on their whistle when making a call?</b>	<input type="checkbox"/> YES <input type="checkbox"/> NO <input type="checkbox"/> Not Observed
<b>Does the official display the basic hand signals throughout the game?</b> <ul style="list-style-type: none"> <li>• Point for direction of play</li> <li>• Stop sign</li> <li>• Ready signal</li> </ul>	<input type="checkbox"/> YES <input type="checkbox"/> NO <input type="checkbox"/> Not Observed
<b>Does the official display proper verbal communication skills throughout the game?</b>	<input type="checkbox"/> YES <input type="checkbox"/> NO <input type="checkbox"/> Not Observed
<b>Does the official have a grasp of 2 man mechanics and proper positioning on the field?</b>	<input type="checkbox"/> YES <input type="checkbox"/> NO <input type="checkbox"/> Not Observed
<b>Does the official demonstrate an understanding of areas of responsibility and on/off ball officiating?</b>	<input type="checkbox"/> YES <input type="checkbox"/> NO <input type="checkbox"/> Not Observed

## APPENDIX VIII: LEVEL 1 US LACROSSE OFFICIALS EVALUATION FORM

Official: \_\_\_\_\_ Evaluator: \_\_\_\_\_ Date of Evaluation: \_\_\_\_\_

Game Level: \_\_\_\_\_ Difficulty of Game:  Easy  Competitive  Difficult  Very Difficult

Officials Current USL Level: --- Home Team: \_\_\_\_\_ Visiting Team: \_\_\_\_\_

**Part 1 – Game Management**

Category	Meets Expectations	Needs Some Improvement	Not Observed	Comments
Does the official display proper time management throughout the course of the game				
Does the official have the ability to keep the game under control				

**Part 2 – Rules Knowledge and Application**

Does the official display knowledge of the rules				
Does the official display proper application of the rules				
Does the official demonstrate sound judgment and consistency throughout the game				

**Part 3 - Mechanics**

Does the official demonstrate proper positioning and mechanics				
Does the official demonstrate proper hand signals and verbal communication when making calls				
Does the official demonstrate hustle and the ability to get into proper positioning				

**Part 4 – Comportment**

Does the official show display a professional attitude and appearance while on the field				
Does the official show the ability to work as a team on the field with their partner				



*Level 1 Officials Evaluation Form*

**Part 5 – Summary**

This official is certified at Level 1 and could advance to Level 2 training and evaluation.	<input type="checkbox"/> Y <input type="checkbox"/> N	With some improvement in Parts 1-4 this official would be ready to be re-evaluated in order to be certified at Level 1.	<input type="checkbox"/> Y <input type="checkbox"/> N
This official is certified at Level 1. With some improvement in parts 1-4 and areas noted, this official would be ready for evaluation and training at Level 2.	<input type="checkbox"/> Y <input type="checkbox"/> N	This official needs to show significant improvement in parts 1-4 before being re-evaluated to be certified at Level 1	<input type="checkbox"/> Y <input type="checkbox"/> N

## APPENDIX VIII: LEVEL 1 US LACROSSE OFFICIALS EVALUATION FORM

This Level 1 evaluation is to be completed by a Certified Official’s Trainer with US Lacrosse. This is the evaluation a new official will need to have completed and passed in order to become a Certified Official with US Lacrosse. In the above evaluation form please keep in mind the two main categories in addition to the “Not Observed” category when observing the official on the field. Also the MGTC feels it is very important to provide written feedback to each official being evaluated. Please make sure you provide any additional feedback for the official in order to provide him with as much information as possible regarding what he should continue to work on during the season. Level 1 certification is the minimum ability required to keep the game safe. Being evaluated does guarantee certification. Please read Part 5 carefully.

Does the official possess proper foul recognition for the level of play?	<input type="checkbox"/> YES <input type="checkbox"/> NO <input type="checkbox"/> Not Observed
Can the official properly conduct a face-off?	<input type="checkbox"/> YES <input type="checkbox"/> NO <input type="checkbox"/> Not Observed
Does the official understand the four primary spots to be on the field in certain situations? <ul style="list-style-type: none"> <li>• Lead                         <ul style="list-style-type: none"> <li>○ Goal Line Extended</li> <li>○ End line and Sideline</li> </ul> </li> <li>• Trail                         <ul style="list-style-type: none"> <li>○ Change of possession</li> <li>○ Settled position</li> </ul> </li> </ul>	<input type="checkbox"/> YES <input type="checkbox"/> NO <input type="checkbox"/> Not Observed
Does the official display a proper strength and use of their whistle?	<input type="checkbox"/> YES <input type="checkbox"/> NO <input type="checkbox"/> Not Observed
Does the official display the proper mechanics after a goal is scored?	<input type="checkbox"/> YES <input type="checkbox"/> NO <input type="checkbox"/> Not Observed
Does the official display proper timing on their whistle when making a call?	<input type="checkbox"/> YES <input type="checkbox"/> NO <input type="checkbox"/> Not Observed
Does the official display these proper hand signals throughout the game? <ul style="list-style-type: none"> <li>• Point for direction of play</li> <li>• Stop sign</li> <li>• Ready signal</li> </ul>	<input type="checkbox"/> YES <input type="checkbox"/> NO <input type="checkbox"/> Not Observed
Does the official display proper verbal communication skills throughout the game?	<input type="checkbox"/> YES <input type="checkbox"/> NO <input type="checkbox"/> Not Observed
Does the official have a basic grasp of 2 man mechanics and proper positioning on the field?	<input type="checkbox"/> YES <input type="checkbox"/> NO <input type="checkbox"/> Not Observed
Does the official demonstrate knowledge and understanding of areas of responsibility and on/off ball officiating?	<input type="checkbox"/> YES <input type="checkbox"/> NO <input type="checkbox"/> Not Observed

**General Comments**



## APPENDIX IX: LEVEL 2 US LACROSSE OFFICIALS EVALUATION FORM

Official: \_\_\_\_\_ Evaluator: \_\_\_\_\_ Date of Evaluation: \_\_\_\_\_

Game Level: ----- Difficulty of Game:  Easy  Competitive  Difficult  Very Difficult

Officials Current USL Level: ----- Home Team: \_\_\_\_\_ Visiting Team: \_\_\_\_\_

**Part 1 – Game Management**

Category	Exceeds Expectations	Meets Expectations	Needs Improvement	Not Observed
Pre-game and Post-game Management				
Time Management During Game				
Control of Game				

**Part 2 – Rules Knowledge and Application**

Knowledge of the Rules				
Application of the Rules				
Judgment				
Consistency				

**Part 3 - Mechanics**

Positioning				
Hand Signals and Communication				
Hustle				

**Part 4 – Uniform and Appearance**

Uniform Appearance				
Physical Appearance				

**Part 5 – Compartment**

Demeanor and Professionalism				
Verbal Communication Skills				
Teamwork				

**Part 6 –Summary**

This official is certified at Level 2 and could advance to Level 3 training and evaluation.	<input type="checkbox"/> Y <input type="checkbox"/> N	With some improvement in Parts 1-5 this official would be ready to be re-evaluated in order to be certified at Level 2.	<input type="checkbox"/> Y <input type="checkbox"/> N
This official is certified at Level 2. With some improvement in parts 1-5 and areas noted, this official would be ready for evaluation and training at Level 3.	<input type="checkbox"/> Y <input type="checkbox"/> N	This official needs to show significant improvement in parts 1-5 before being re-evaluated to be certified at Level 2.	<input type="checkbox"/> Y <input type="checkbox"/> N

**Part 7 – General Comments**





*Level 2 Officials  
Evaluation Form*

## APPENDIX IX: LEVEL 2 US LACROSSE OFFICIALS EVALUATION FORM

This Level 2 evaluation is to be completed by a Certified Official's Trainer with US Lacrosse. This is the evaluation a Level 1 official will need to have completed and passed in order to become a Level 2 Certified Official with US Lacrosse. In the above evaluation form please keep in mind the three main categories and in addition to the "Not Observed" category when observing the official on the field. Also the MGTC feels it is very important to provide written feedback to each official being evaluated. Please make sure you provide any additional feedback for the official in order to provide him with as much information as possible regarding what he should continue to work on during the season. Being evaluated does not guarantee certification. Please read Part 6 carefully.

<b>Was the official active in pre-game activities and duties with the rest of the crew?</b>	<input type="checkbox"/> YES	<input type="checkbox"/> NO	<input type="checkbox"/> Not Observed
<b>Does the official employ the "play-on" technique properly?</b>	<input type="checkbox"/> YES	<input type="checkbox"/> NO	<input type="checkbox"/> Not Observed
<b>Does the official have a strong grasp of off-sides?</b>	<input type="checkbox"/> YES	<input type="checkbox"/> NO	<input type="checkbox"/> Not Observed
<b>Does the official understand responsibility for counts based on position on the field?</b>	<input type="checkbox"/> YES	<input type="checkbox"/> NO	<input type="checkbox"/> Not Observed
<b>Does the official understand the concept of "Advantage/Disadvantage?"</b>	<input type="checkbox"/> YES	<input type="checkbox"/> NO	<input type="checkbox"/> Not Observed
<b>Does the official recognize and call any necessary player safety calls?</b>	<input type="checkbox"/> YES	<input type="checkbox"/> NO	<input type="checkbox"/> Not Observed
<b>Does the official understand the importance of communication to players and coaches and use it to properly manage the game?</b>	<input type="checkbox"/> YES	<input type="checkbox"/> NO	<input type="checkbox"/> Not Observed
<b>Does the official practice good preventative officiating by using the proper tools and techniques?</b>	<input type="checkbox"/> YES	<input type="checkbox"/> NO	<input type="checkbox"/> Not Observed
<b>Does the official have a solid grasp of 2 man mechanics and proper positioning on the field?</b>	<input type="checkbox"/> YES	<input type="checkbox"/> NO	<input type="checkbox"/> Not Observed
<b>Does the official show purposeful movement on the field?</b>	<input type="checkbox"/> YES	<input type="checkbox"/> NO	<input type="checkbox"/> Not Observed
<b>Does the official show and have a strong understanding of areas of responsibility? (on/off ball)</b>	<input type="checkbox"/> YES	<input type="checkbox"/> NO	<input type="checkbox"/> Not Observed
<b>Does the official show and use solid hand signals throughout the game?</b>	<input type="checkbox"/> YES	<input type="checkbox"/> NO	<input type="checkbox"/> Not Observed
<b>Is the official dressed in a complete uniform that is clean and neat in appearance?</b>	<input type="checkbox"/> YES	<input type="checkbox"/> NO	<input type="checkbox"/> Not Observed
<b>Is the official in good physical condition?</b>	<input type="checkbox"/> YES	<input type="checkbox"/> NO	<input type="checkbox"/> Not Observed
<b>Does the official carry himself in a respectful and professional manner?</b>	<input type="checkbox"/> YES	<input type="checkbox"/> NO	<input type="checkbox"/> Not Observed
<b>Can the official adjust his officiating depending on the level of play?</b>	<input type="checkbox"/> YES	<input type="checkbox"/> NO	<input type="checkbox"/> Not Observed

# APPENDIX X: LEVEL 3 US LACROSSE OFFICIALS EVALUATION FORM

Official: \_\_\_\_\_ Evaluator: \_\_\_\_\_ Date of Evaluation: \_\_\_\_\_

Game Level: ----- Difficulty of Game:  Easy  Competitive  Difficult  Very Difficult

Officials Current USL Level: 1 Home Team: \_\_\_\_\_ Visiting Team: \_\_\_\_\_

Scores below are marked on a scale of 1 through 5. These scores translate into the following:

5 – Excellent      4 – Very Good      3 – Good      2 – Fair      1 – Poor

These scores are to be based on the level of proficiency expected for the caliber of play being observed. A score of 3 indicates that performance is up to par with the expected level for the caliber of play, a 4 is given where the referee fully meets expectations. If they encountered a challenge and responded well, and or otherwise exceeded expectations a score of 5 is given. Scores of 1 or 2 mean that deficiencies were observed in the official’s performance and there is room for improvement. If an official receives a score of 1 or 2 please make sure to note that in “Part 8, General Comments”

**Part 1 – Game Management**

Category	Score
Pre-game and Post-game Management	3
Time Management During Game	3
Control of Game	3

**Part 2 – Rules Knowledge and Application**

Category	Score
Knowledge of the Rules	3
Application of the Rules	3
Judgment	3
Consistency	3

**Part 3 - Mechanics**

Category	Score
Positioning	3
Hand Signals and Crew Communication	3
Hustle	3

**Part 4 – Uniform and Appearance**

Category	Score
Uniform Appearance	3
Physical Appearance	3

**Part 8- General Comments**





*Level 3 Officials  
Evaluation Form*

**Part 5 – Comportment**

Category	Score
Professionalism and Demeanor	3
Verbal Communication Skills	3
Teamwork	3

**Part 6 – Overall Score**

Overall Score From Parts 1-5	75%
------------------------------	-----

**Part 7 – Potential**

Category	
This official is certified at Level 3 and could advance to a higher level of training and evaluation.	<input type="checkbox"/> Y <input type="checkbox"/> N
This official is certified at Level 3. With some improvement in parts 1-5 and areas noted, this official would be ready for evaluation and training at a higher level	<input type="checkbox"/> Y <input type="checkbox"/> N
With some improvement in Parts 1-5 this official would be ready to be re-evaluated in order to be certified at Level 3.	<input type="checkbox"/> Y <input type="checkbox"/> N
This official needs to show significant improvement in parts 1-5 before being re-evaluated to be certified at Level 3.	<input type="checkbox"/> Y <input type="checkbox"/> N

## APPENDIX X: LEVEL 3 US LACROSSE OFFICIALS EVALUATION FORM

This Level 3 evaluation is to be completed by a Certified Official's Trainer with US Lacrosse. This is the evaluation a Level 2 official will need to have completed and passed in order to become a Level 3 Certified Official with US Lacrosse. In the above evaluation please keep in mind that it is a numerical score of 1-5 for each category which then in turns translates into a 100 point overall score given. The final score is a final score that reflects the evaluators overall assessment of the official's performance. A score of 75+ represents a minimum level of expected performance for level 3. 69 or below indicates the official has struggled in this game or at this level and needs to be reevaluated. A score of 80+ indicates the official fully meets expectations for the level of play with a score of 90+ being an official who responded well to challenges and exceeded expectations in this game or at this level of play. Being evaluated does not guarantee certification. Please read Part 7 carefully.

<b>Was the official active in his pre-game with his crew? (If the R did the official conduct a proper pre-game with his crew?)</b>	<input type="checkbox"/> Yes <input type="checkbox"/> No <input type="checkbox"/> Not Observed
<b>Does the official have a solid grasp of 3 man mechanics?</b>	<input type="checkbox"/> Yes <input type="checkbox"/> No <input type="checkbox"/> Not Observed
<b>Does the official understand and demonstrate proper "yo-yoing" with Lead when he is single side?</b>	<input type="checkbox"/> Yes <input type="checkbox"/> No <input type="checkbox"/> Not Observed
<b>Does the official sweep the box properly when coming up the field as trail?</b>	<input type="checkbox"/> Yes <input type="checkbox"/> No <input type="checkbox"/> Not Observed
<b>Did the official properly assist lead on the goal area when necessary?</b>	<input type="checkbox"/> Yes <input type="checkbox"/> No <input type="checkbox"/> Not Observed
<b>As single did the official stop at the midfield cone for the right amount of time depending on "the break?"</b>	<input type="checkbox"/> Yes <input type="checkbox"/> No <input type="checkbox"/> Not Observed
<b>Does the official have a strong understanding of areas of responsibility? (On/off ball, dead ball situations)</b>	<input type="checkbox"/> Yes <input type="checkbox"/> No <input type="checkbox"/> Not Observed
<b>Can this official successfully work with partners that are at a lower level?</b>	<input type="checkbox"/> Yes <input type="checkbox"/> No <input type="checkbox"/> Not Observed
<b>Does the official have a good understanding of the flow of the game?</b>	<input type="checkbox"/> Yes <input type="checkbox"/> No <input type="checkbox"/> Not Observed
<b>Do the coaches and fellow officials respect his ability at this level of play?</b>	<input type="checkbox"/> Yes <input type="checkbox"/> No <input type="checkbox"/> Not Observed
<b>Does the official handle tough situations calmly and with conviction?</b>	<input type="checkbox"/> Yes <input type="checkbox"/> No <input type="checkbox"/> Not Observed
<b>Is the official and good physical condition?</b>	<input type="checkbox"/> Yes <input type="checkbox"/> No <input type="checkbox"/> Not Observed
<b>Does the official carry himself in a respectful and professional manner?</b>	<input type="checkbox"/> Yes <input type="checkbox"/> No <input type="checkbox"/> Not Observed
<b>Can the official adjust his officiating depending on the level of play?</b>	<input type="checkbox"/> Yes <input type="checkbox"/> No <input type="checkbox"/> Not Observed







